



DEWETRON

NEX[DAQ]

TECHNICAL REFERENCE



ISO 9001



Copyright © DEWETRON GmbH

This document contains information which is protected by copyright. All rights are reserved. Reproduction, adaptation, or translation without prior written permission is prohibited, except as allowed under the copyright laws.

All trademarks and registered trademarks are acknowledged to be the property of their owners.

Preface

Welcome to the world of DEWETRON!

Congratulations on your new device! It will supply you with accurate, complete and reproducible measurement results for your decision making.

Look forward to the easy handling and the flexible and modular use of your DEWETRON product and draw upon more than 30 years of DEWETRON expertise in measurement engineering.

This guide has been prepared to help you get the most from your investment, starting from the day you take it out of the box, and extending for years into the future.

This guide includes important startup notes, as well as safety notes and information about keeping your DEWETRON system in good working condition over time. However, this manual cannot and is not intended to replace adequate training.

The operating as well as the safety and care instructions contained in this documentation must be observed by the user. Faultless operation can only be guaranteed by observing these instructions.

Scope of supply

- ▶ 1 NEX[DAQ] measurement device
- ▶ 1 USB-C PD power supply cord
- ▶ 1 USB3.2 USB-A to USB-C cord

TABLE OF CONTENTS

Preface	3	CAN 1–2	20
Welcome to the world of DEWETRON!	3	Acquisition LED	21
Scope of supply	3		
Safety	6	Signal connection	22
Safety instructions	6	Direct signal connection	22
General safety instructions	6	Analog input.....	22
Electrical safety instructions	7	Digital input DI1–DI8 CNT (A, B, Z)	27
Ambient safety notices.....	7	Counter input.....	28
Safety notices during operation	8	CAN input.....	29
Standards and norms	8	Connect XR series modules to NEX[DAQ].....	29
Typographic conventions	8	Signal connection via MSI	30
Safety and warning notices	8	MSI2-V-600.....	30
Notices	8	MSI2-STG.....	31
Symbols.....	9	MSI-BR-ACC.....	35
		MSI2-CH-x	36
		MSI2-TH-x.....	37
		MSI-BR-RTD.....	39
		MSI2-LVDT.....	41
		MSI2-LA-250R-20mA.....	43
General information	10		
Environmental considerations	10	Working with the system	45
Problematic network stacks	10	Mounting options	45
Warranty information	10	Using NEX[DAQ] on a laptop/PC	45
Legal information	10	Requirements.....	45
Restricted rights legend	10	Install driver (USB only).....	45
Legal disclaimer.....	10	Installing OXYGEN	46
Printing history	11	Advanced configuration	49
Main system	12	Troubleshooting	54
Key facts	12		
System specifications	12	Accessoires	55
Dimensions*	17	Modular smart interfaces (MSI).....	55
System overview	17	Further accessories	55
Connections and ports	18	Maintenance and service	56
USB-C data	18	Service interval	56
USB-C PD IN	18	Cleaning the system	56
Power	19	Firmware upgrade	56
Ethernet	19	Updates	58
Counter 1–4	19		
Channels 1–8	20		
DIO	20		

TABLE OF CONTENTS

Windows and antivirus/security software	58
Software updates	58
IP settings recovery	59
Training	59
Calibration	59
Support	59
Service and repairs	59
Letter of volatility	61
Volatile memory	61
Non-volatile memory	61
Appendix	62
General	62
Fundamental frequency	62
Harmonic frequencies	62
Spurs	62
Noise	62
DC component	62
Testing	63
General information about testing	63
SNR	63
SFDR	64
ENOB	65
THD	65
CMRR	66
Phase mismatch	67
Glossary	68
Isolation voltage	68
Input ranges	68
Rated input voltage to earth	68
Common mode voltage	70
Overvoltage protection	70
Max. DC voltage @ AC coupling	71
Bus pin fault protection	71
IP rating	71
CE certificate of conformity	73

SAFETY

Safety

Safety instructions

The following section contains warning and safety instructions that must be observed by the user. Faultless operation can only be guaranteed if these instructions are observed.

General safety instructions

- ▶ Use this system under the terms of the specifications only to avoid any possible danger. If the unit is used in a manner not specified by the manufacturer the protection can be impaired.
- ▶ Maintenance is to be executed by qualified staff only.
- ▶ DO NOT use the system if equipment covers or shields are removed. If you assume the system is damaged, have it examined by authorized personnel only.
- ▶ Any other use than described above may damage your system and is attended with dangers such as short-circuits, fire or electric shocks.
- ▶ The whole system must not be changed, rebuilt or opened.
- ▶ Reinstall filler panels of unused TRION slots to guarantee proper cooling of the installed modules. The warranty is void if the modules overheat due to missing filler panels.
- ▶ If you assume a more riskless use is not provided anymore, the system has to be rendered inoperative and should be protected against inadvertent operation. It is assumed that a more riskless operation is not possible anymore, if
 - the system is damaged obviously or causes strange noises.
 - the system does not work anymore.
 - the system has been exposed to long storage in adverse environmental.
 - the system has been exposed to heavy shipment strain.
- ▶ The warranty is void if damages caused by disregarding this manual. For consequential damages NO liability will be assumed.
- ▶ The warranty is void if damages to property or persons caused by improper use or disregarding the safety instructions.
- ▶ Unauthorized changing or rebuilding the system is prohibited due to safety and permission reasons (CE).
- ▶ Prevent using metal bare wires as there is a risk of short-circuit and fire hazard.
- ▶ DO NOT use the system before, during or shortly after a thunderstorm (risk of lightning and high energy overvoltage). An advanced range of application under certain conditions is allowed with therefore designed products only. For details refer to the specifications.
- ▶ Make sure that your hands, shoes, clothes and as well as the floor, the system or measuring leads, integrated circuits etc. are dry.
- ▶ Use measurement leads or measurement accessories aligned to the specification of the system only. Fire hazard in case of overload.
- ▶ Do not disassemble the system. There is a high risk of getting a perilous electric shock. Capacitors still might charged, even the system has been removed from the power supply.
- ▶ The measuring systems are not designed for use at humans and animals.
- ▶ Contact a professional if you have doubts about the method of operation, safety or the connection of the system.
- ▶ Handle the product with care. Shocks, hits and dropping it even from an already lower level may damage your system.
- ▶ Also consider the detailed technical reference manual as well as the security advices of the connected systems.

Electrical safety instructions

- ▶ With this product, only use the power cable delivered or defined for the host country.
- ▶ DO NOT connect or disconnect sensors, probes or test leads, as these parts are connected to a voltage supply unit.
- ▶ The system is grounded via a protective conductor in the power supply cord. To avoid electric shocks, the protective conductor has to be connected with the ground of the power network. Before connecting the input or output connectors of the system, make sure that there is a proper grounding to guarantee potential free usage. For countries, in which there is no proper grounding, refer to your local legally safety regulations for safety use.
- ▶ DC systems: Every DC system has a grounding connected to the chassis (black safety banana plug).
- ▶ Note the characteristics and indicators on the system to avoid fire or electric shocks. Before connecting the system, carefully read and understand the corresponding specifications in the product manual.
- ▶ The inputs are not, unless otherwise noted (CATx identification), for connecting to the main circuits of category II, III and IV. The measurement category can be adjusted depending on module configuration.
- ▶ The power cord or the main power switch separates the system from the power supply. Do not block the power cord or main switch, since it has to be accessible for the users.
- ▶ Any direct voltage output is protected with a fuse against short-circuits and reverse-polarity, but is NOT galvanically isolated (except it is explicit marked on the system).
- ▶ Supply overvoltage category is II.
- ▶ The system must be connected and operated to an earthed wall socket at the AC mains power supply only (except for DC systems).
- ▶ DO NOT touch any exposed connectors or components if they are live wired. The use of metal bare wires is not allowed. There is a risk of short-circuits and fire hazard.
- ▶ The assembly of the system is equivalent to protection class I. For power supply, only the correct power socket of the public power supply must be used, except the system is DC powered.
- ▶ Be careful with voltages $>25 V_{AC}$ or $>35 V_{DC}$. These voltages are already high enough in order to get a perilous electric shock by touching the wiring.
- ▶ Unless otherwise stated, the maximum input voltage for measuring cards is $70 V_{DC}$ and $46.7 V_{PEAK}$
- ▶ The electrical installations and equipments in industrial facilities must be observed by the security regulations and insurance institutions.

Ambient safety notices

- ▶ This product is intended for use in industrial locations. As a result, this product may cause interference if used in residential areas. Such use must be avoided unless the user takes special measures to reduce electromagnetic emissions to prevent interferences to the reception of radio and television broadcasts.
- ▶ Do not switch on the system after transporting it from a cold into a warm room and vice versa. The thereby created condensation may damage your system. Acclimatise the system unpowered to room temperature.
- ▶ Any use in wet rooms, outdoors or in adverse environmental condition is not allowed. Adverse environmental conditions are:
 - Moisture or high humidity
 - Dust, flammable gases, fumes or dissolver
 - Thunderstorm or thunderstorm conditions (except assembly PNA)
 - Electrostatic fields etc.
- ▶ DO NOT use the system in rooms with flammable gases, fumes or dust or in adverse environmental conditions.
- ▶ Direct exposure of any DEWETRON product to strong sunlight or other heat radiation shall be prevented, as this could excessively heat up the product and lead to permanent damage of the product.
- ▶ The use of the measuring system in schools and other training facilities must be observed by skilled personnel.

SAFETY

Safety notices during operation

- ▶ During the use of the system, it might be possible to access another parts of a more comprehensive system. Read and follow the safety instructions provided in the manuals of all other components regarding warning and security advices for using the system.
- ▶ The product heats during operation. Make sure there is adequate ventilation. Ventilation slots must not covered. Only fuses of the specified type and nominal current may be used. The use of patched fuses is prohibited.

Standards and norms

This product has left the factory in safety-related flawless and proper condition. In order to maintain this condition and guarantee safety use, the user has to consider the security advices and warnings in this manual.

EN 61326-3-1:2008

IEC 61326-1 applies to this part of IEC 61326 but is limited to systems and equipment for industrial applications intended to perform safety functions as defined in IEC 61508 with SIL 1-3.

The electromagnetic environments encompassed by this product family standard are industrial, both indoor and outdoor, as described for industrial locations in IEC 61000-6-2 or defined in 3.7 of IEC 61326-1.

Equipment and systems intended for use in other electromagnetic environments, for example, in the process industry or in environments with potentially explosive atmospheres, are excluded from the scope of this product family standard, IEC 61326-3-1.

Devices and systems according to IEC 61508 or IEC 61511 which are considered as “operationally welltried”, are excluded from the scope of IEC 61326-3-1.

Fire-alarm and safety-alarm systems, intended for protection of buildings, are excluded from the scope of IEC 61326-3-1.

Typographic conventions

Safety and warning notices

WARNING



Indicates a hazardous situation that, if not avoided, could result in death or serious injury.

CAUTION



Indicates a hazardous situation that, if not avoided, could result in minor or moderate injury.

Notices

NOTICE

This text indicates situations or operation errors which could result in property damage or data loss.

INFORMATION

This text indicates important information or operating instructions. Not observing these instructions could inhibit or impede you from successfully completing the tasks described in this documentation.

Symbols



Denotes a warning that alerts you to take precautions to avoid injury. When this symbol is shown on the product, refer to the technical reference manual (ISO 7000-4034; 2004-01).



Indicates hazardous voltages.



Observe precautions for handling electrostatic sensitive devices.



Indicates the chassis terminal (IEC 60417-5020; 2002-10).



Direct current (IEC 60417-5031; 2002-10)



Alternate current (IEC 60417-5032; 2002-10)



Both direct and alternating current (IEC 60417-5033; 2002-10)



Three-phase alternating current (IEC 60417-5032-1; 2002-10)



Protective conductor terminal (IEC 60417-5019; 2006-08)



Equipment protected throughout by double insulation or reinforced insulation (IEC 60417-5172; 2003-02)



On (power) (IEC 60417-5007; 2002-10)



Off (power) (IEC 60417-5008; 2002-10)

GENERAL INFORMATION

General information

Environmental considerations

The following information refers to the environmental impact of the product and the product end-of-life handling. Observe the following guidelines when recycling a DEWETRON system:

▶ System and components recycling



The production of these components has required the extraction and use of natural resources. The substances contained in the system could be harmful to your health and to the environment if the system is improperly handled at its end of life. Recycle this product in an appropriate way to avoid an unnecessary pollution of the environment and to keep natural resources.

This symbol indicates that this system complies with the European Union's requirements according to Directive 2002/96/EC on Waste of Electrical and Electronic Equipment (WEEE). Further information about recycling can be found on the DEWETRON website (www.dewetron.com).

▶ Restriction of hazardous substances

This product has been classified as Monitoring and Control equipment, and is outside the scope of the 2011/65/EU RoHS Directive. This product is known to contain lead.

Problematic network stacks

Often intrusive IT software or network processes can interfere with the primary function of the DEWETRON system: to record data. Therefore we recommend strongly against the installation of IT/MIS software and running their processes on any DEWETRON data acquisition system, and cannot guarantee the performance of our systems if they are so configured.

Warranty information

A copy of the specific warranty terms applicable to your DEWETRON product and replacement parts can be obtained from your local sales and service office.

Legal information

Restricted rights legend

Use Austrian law for duplication or disclosure.

DEWETRON GmbH
Parking 4
8074 Grambach
Austria

TRION and OXYGEN are trademarks of DEWETRON GmbH.

Any other trademarks and registered trademarks are acknowledged to be the property of their owners.

Legal disclaimer

The information contained in this document is subject to change without notice.

DEWETRON GmbH (DEWETRON) shall not be liable for any errors contained in this document.

DEWETRON MAKES NO WARRANTIES OF ANY KIND WITH REGARD TO THIS DOCUMENT, WHETHER EXPRESS OR IMPLIED. DEWETRON SPECIFICALLY DISCLAIMS THE IMPLIED WARRANTIES OF MERCHANTABILITY AND FITNESS FOR A

GENERAL INFORMATION

PARTICULAR PURPOSE. DEWETRON shall not be liable for any direct, indirect, special, incidental, or consequential damages, whether based on contract, tort, or any other legal theory, in connection with the furnishing of this document or the use of the information in this document.

Printing history

Refer to the page bottom for printing version.

Copyright © DEWETRON GmbH

This document contains information which is protected by copyright. All rights are reserved. Reproduction, adaptation, or translation without prior written permission is prohibited, except as allowed under the copyright laws.

MAIN SYSTEM

Main system

Key facts

- ▶ Portable data acquisition system
- ▶ Rugged industrial design
- ▶ 8 versatile analog input channels
- ▶ 4 counter, 2 CAN-FD interfaces
- ▶ Programmable sensor supply 2 to 24 V
- ▶ TEDS and MSI support
- ▶ 24-bit; 200 kS/s or 1 MS/s

System specifications

General specifications	
Synchronization	Via Ethernet; PTP/IEEE1588
Cooling	Passive; no fan
Isolation	Ethernet, USB and power supply are isolated from input channels
Channel-to-channel isolation	No
Data rate	40 MB/s
MTBF (MIL-HDBK-217 F, GB)	137,215 h
Dimensions (l x w x h)	242 x 120 x 43.3 mm (9.52 x 4.72 x 1.7 in)
Weight	1250 g (2.76 lbs)
Interfaces	
Ethernet	10/100/1000BASE-TX Gigabit Ethernet (2x)
– Ethernet topology	Dasychain; Star
– Ethernet connector	Industrial Ethernet M12 X-coded
– LAN configuration	DHCP or static IP
USB	USB 2.0; USB 3.0; USB-C
– USB connector	USB-C with screw terminals
Configuration	
Analog in	8 channels with: bridge excitation; sensor supply; TEDS/MSI support; 9-pin D-SUB female
Counter	4 encoder input at LEMO 1B 8 auxiliary counter for frequency measurement on DIO connector (37-pin D-SUB female)
Digital in	8 on DIO connector
Digital out	4 on DIO connector
CAN	2 CAN-FD; 9-pin D-SUB male
Environmental specifications	
Operating temperature	-20 °C to +70 °C
Humidity	10 % to 90 %, non condensing
Ingress protection class according to EN 60721-3-2:2018	IP67 (see IP rating on page 71)

Tab. 1: General specifications

Vibration test EN 60068-2-6:2008	Shape	Sine
	Frequency range	10–150 Hz
	Acceleration	20 m/s ²
	Sweep rate	1 oct./min.
	Duration	20 cycles each axis (X, Y, Z)
Vibration test EN 60721-3-2:2018 Class 2M5	Shape	Random
	Total frequency range	10–2000 Hz
	Acceleration spectral density	1–20 Hz: 3 (m/s ²) ² /Hz 500–2000 Hz: 1 (m/s ²) ² /Hz
	RMS value of acceleration	5.015 g
	Duration	30 min per axis
Shock test EN 60068-2-27:2009	Pulse shape	Half-sine
	Acceleration amplitude	30 g
	Duration of the pulse	11 ms
	Number of shocks	18 (3 shocks in two directions of x, y and z axis each)
Shock test EN 60068-2-27:2009	Pulse shape	Half-sine
	Acceleration amplitude	50 g
	Duration of the pulse	6 ms
	Number of shocks	18 (3 shocks in two directions of x, y and z axis each)

Tab. 1: General specifications













Power supply		
Power supply inlets		USB-PD, PoE, Lemo
Power buffer		0.5 s
Power consumption		Typ. 12 W without sensor supply; up to 20 W with sensor supply
LEMO	Connector	LEMO 1B
	Isolated power supply	10 to 32 V; buffered for 0.5 s in case of voltage drop
	Rated input voltage	DC (9 to 36 V _{DC})
USB-PD	Connector	USB-C Type “PD-IN”
	Standard	USB-PD 3.0
	Power supply requirements	USB-PD 3.0 compliant power supply with 12 V, 15 V or 20 V; at least 36 W
PoE	Supported standards	PoE Plus (802.3at-2009); PoE (802.3bt-2018)
	Power supply requirements	PoE Plus (802.3at-2009); PoE (802.3bt-2018) compliant with at least 24 W

Tab. 2: Power supply

Digital in	
Digital input	8 CMOS/TTL compatible digital inputs; weak pull-up via 100 kΩ
Overvoltage protection	±30 V, 50 V (for 100 ms)

Tab. 3: Digital in specifications

MAIN SYSTEM

Input types		Input	Sensor excitation	Bandwidth	Accuracy	Sensor connection
Direct	 Voltage	100 mV to 100 V	2 to 24 V	DC to 250 kHz	±0.05 %	D-SUB-9
	 Bridge	1 mV/V to 100 mV/V full bridge; half bridge	1 to 10 V	DC to 130 kHz	±0.05 %	D-SUB-9
	 Counter	Event counting, waveform timing, encoder mode (X1, X2 and X4)	12 V	-	-	LEMO 1B
	 CAN	CAN 2.0B / CAN-FD	12 V	-	-	D-SUB-9
	 Digital in	TTL	12 V/5 V	-	-	D-SUB-37
MSI	 MSI2-250R-20mA	4 to 20 mA sensors	2 to 24 V	DC to 250 kHz	±0.1 %	Miniature spring terminals
	 MSI2-STG	Bridge-type sensors; full-bridge, half-bridge, quarter bridge 120 Ω and 350 Ω	5 V and 10 V	60 kHz	±0.1 %	Miniature spring terminals
	 MSI2-LVDT	LVDT and RVDT sensors, 5- or 6-wire connection	3 V at 2.5, 5 or 18 kHz	1 kHz	±0.1 %	Soldering pads
	 MSI-BR-ACC	IEPE® sensors, typ. accelerometer, microphone	4 mA	1.4 Hz to 250 kHz	±0.2 %	BNC
	 MSI2-CH-x	Charge type sensors up to 100 000 pC	n/a	0.08 Hz to 250 kHz	±0.5 %	BNC
	 MSI2-TH-x	Thermocouple sensors; Standard models for type K, J, T, others on request	n/a	DC to 250 kHz	±1 °C	Mini TC socket
	 MSI2-V-600	Voltage up to 600 VDC	n/a	DC to 60 kHz	±0.1 %	Banana sockets
	 MSI-BR-RTD	RTD sensors; Pt100, Pt200, Pt500, Pt1000, Pt2000; 2, 3 and 4 wire connection	1.25 mA	DC to 10 kHz	±0.1 %	Binder 712 series 5-pin socket

Tab. 4: Input specifications

Analog channel specification			
Input connector	8x 9-pin female D-SUB		
Rated input voltage	33 V _{RMS} , 46.7 V _{PEAK} , 70 V _{DC}		
Input range	100 mV to 100 V; freely programmable		
Sampling	200 kS/s, 24-bit (optional: 1 MS/s, 24-bit)		
Voltage input accuracy ¹⁾	≤10 V	DC to 1 kHz	±0.05 % of reading ±0.02 % of range ±50 μV
		>1 kHz to 10 kHz	±0.5 % of reading ±0.02 % of range ±50 μV
	≥10 V	DC to 1 kHz	±0.05 % of reading ±0.02 % of range ±50 μV
		>1 kHz to 10 kHz	±1 % of reading ±0.02 % of range ±50 μV
Gain drift	Typ. 20 ppm/°C; max. 40 ppm/°C		
Offset drift	Typ. 1 μV/°C + 10 ppm of range; max. 3.5 μV/°C + 20 ppm of range		

Tab. 5: Analog channel specifications

Analog channel specification																
Linearity	<50 ppm															
CMRR	Typ. CMRR at 10 V range: 90 dB @ 50 Hz; 90 dB @ 1kHz; 70 dB @ 10 kHz; 50 dB @ 100 kHz															
Crosstalk	Typ. better 110 dB															
Input noise	0 to 10 Hz				1.5 μV_{pp}											
	Noise density				19 nV/ $\sqrt{\text{Hz}}$											
Signal-to-noise ratio; spurious free SNR	100 mV range				1 V range				10 V range				100 V range			
Effective number of bits ²⁾ ; filter=auto	SNR	SFDR ³⁾	ENOB ⁴⁾	Noise	SNR	SFDR ³⁾	ENOB ⁴⁾	Noise	SNR	SFDR ³⁾	ENOB ⁴⁾	Noise	SNR	SFDR ³⁾	ENOB ⁴⁾	Noise
Sample rate	[dB]	[dB]	[Bit]	[mV _{pp}]	[dB]	[dB]	[Bit]	[mV _{pp}]	[dB]	[dB]	[Bit]	[mV _{pp}]	[dB]	[dB]	[Bit]	[mV _{pp}]
1 kS/s	105	125	17.1	0.0028	123	145	20.1	0.0035	129	150	21.2	0.016	126	144	20.6	0.24
10 kS/s	100	125	16.3	0.006	117	145	19.1	0.008	122	147	19.9	0.045	118	144	19.3	0.6
100 kS/s	92	125	15.0	0.015	109	145	17.8	0.021	112	147	18.3	0.16	109	144	17.8	2.4
200 kS/s	89	125	14.6	0.02	106	145	17.3	0.032	109	147	17.8	0.23	106	144	17.3	3.4
Filter = OFF	86	120	14.1	0.033	99	138	16.1	0.09	100	143	16.3	0.7	99	140	16.1	8.3
Input impedance	0 to 10 V range				200 M Ω											
	>10 to 100 V range				2 M Ω											
Input configuration	Differential															
Input coupling	DC															
Common mode voltage	<1 V range				$\pm 10 V_{DC}$											
	1 to 10 V range				$\pm 15 V_{DC}$											
	>10 to 100 V range				$\pm 100 V_{DC}$											
Overvoltage protection	0 to 10 V range				$\pm 50 V_{DC}$											
	>10 to 100 V range				$\pm 200 V_{DC}$											
Analog bandwidth	1 to 100 V range				250 kHz											
	100 mV range				130 kHz (bridge mode)											
Low pass filter (-3 dB, digital)	1 Hz to 40 % of sample rate; freely programmable or OFF															
	Characteristic				Bessel or Butterworth											
	Filter order				2 nd , 4 th , 6 th , 8 th											
	Filter setting AUTO				30 % of sample rate with 8 th order Bessel											

Tab. 5: Analog channel specifications

1) 1 year accuracy 23 °C ± 5 °C

2) LP filter in auto mode

3) SFDR excluding harmonics

4) ENOB calculated from SNR

Bridge functions		
Supported bridge types	Full bridge	4 or 6 wire
	Half bridge	3 or 5 wire
	Quarter bridge	With optional MSI2-STG 120 Ω and 350 Ω
Bridge resistance	5 V excitation	120 to 10 k Ω
	10 V excitation	300 to 10 k Ω
Autom. bridge balance	± 400 % of range	

Tab. 6: Bridge functions

MAIN SYSTEM

Sensor excitation		
Bridge excitation	V bridge	1 to 10 V freely programmable; balanced around ground; remote sense support
	1 year accuracy	±1 mV
	Drift	25 ppm/°C
	Current limit	40 mA
	Protection	Continuous short to ground
	Load and line regulation error	±0.002 % with sense lines connected
Sensor supply	V sensor	2 to 24 V freely programmable in 100 mV steps; referenced to GND
	Accuracy	±3 %
	Limit	Max. 100 mA; max. 0.5 W
	Protection	Continuous short to ground
	Total sensor supply limit	All sensor supplies combined, including Counter and CAN bus sensor supply, must not exceed 5 W.

Tab. 7: Sensor excitation

CAN	
CAN bus	2x CAN bus at male 9-pin D-SUB
CAN specification	CAN 2.0B; CAN FD 1.0
CAN physical layer	High-speed
Bus pin fault protection	±36 V
Termination	Programmable: high impedance or 120 Ω

Tab. 8: CAN specifications

Counter		
4x full featured counter	Connector	4x LEMO connector female, EGG.1B.307.CLL
	Input signal	8 CMOS/TTL compatible digital inputs; weak pullup via 100 kΩ
	Sensor supply	12V ±5 % 100 mA
	Modes	Event counting; gated event counting; up/down counting; frequency; dutycycle; edge seperation; encoder (x1, x2, x4)
	Filter	0.1 to 100 μs
8x basic counter	Connector	Shared with Digital IN on 37-pin D-SUB
	Modes	Event counting; Frequency;
	Filter	0.1 to 100 μs

Tab. 9: Counter specifications

Dimensions*

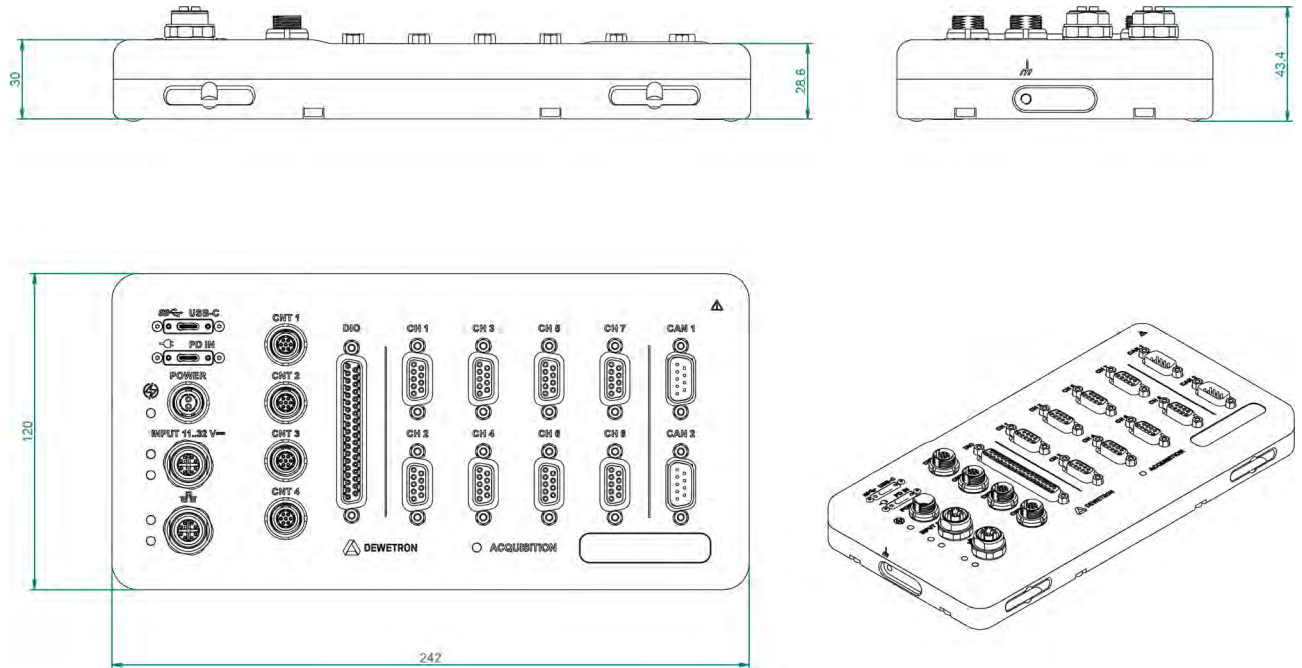

*) Dimensions in mm (1 inch = 25.4 mm)

Fig. 1: Dimensions NEX[DAQ]

System overview

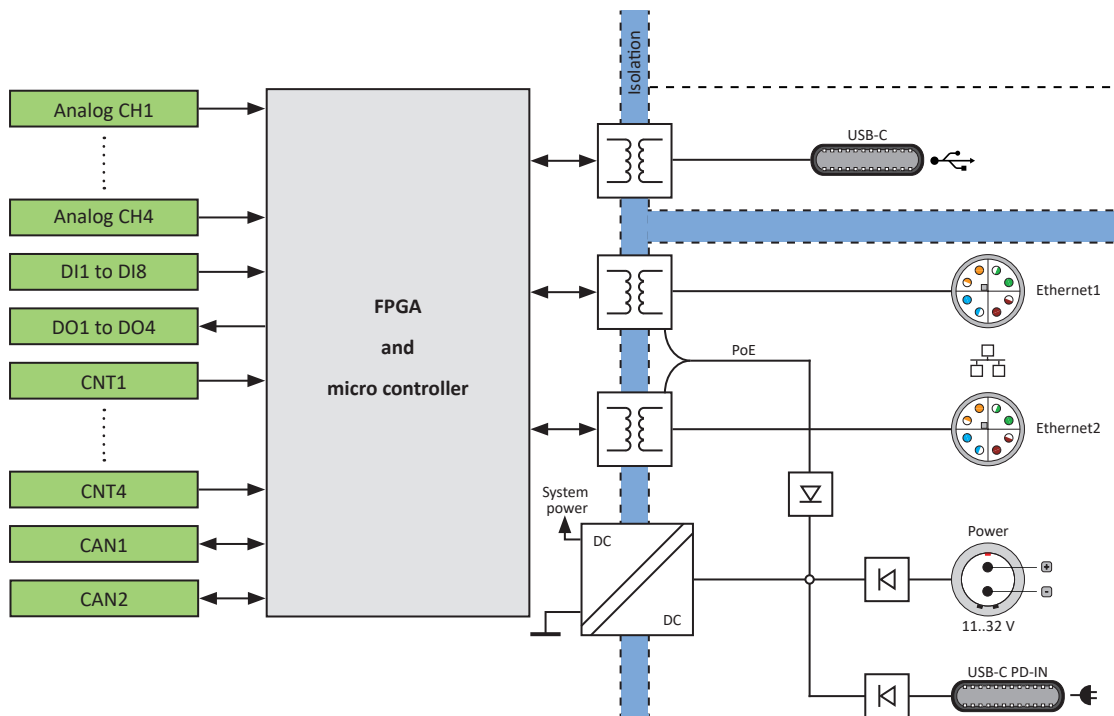

Fig. 2: System overview

CONNECTIONS AND PORTS

Connections and ports

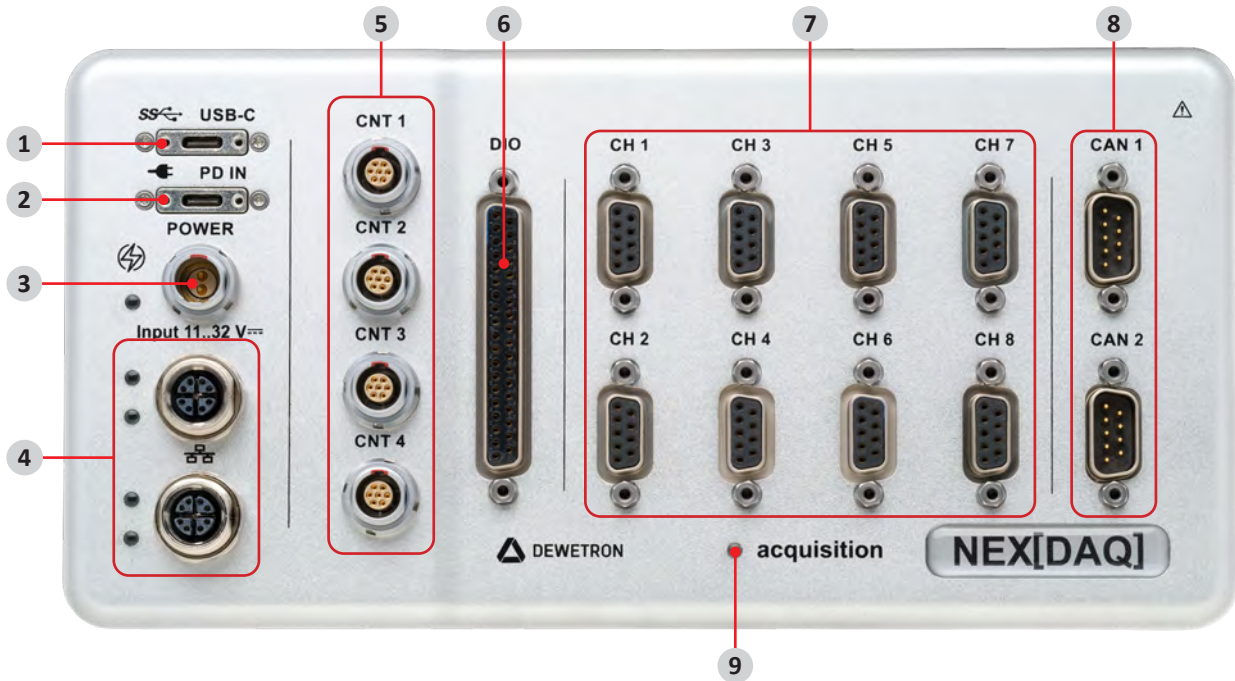

Fig. 3: NEX[DAQ] connectors and ports

- | | |
|--------------------------------|------------------------------------|
| 1. USB-C data | 6. DIO |
| 2. USB-C PD IN | 7. Channels 1–8 |
| 3. Power | 8. CAN 1–2 |
| 4. Ethernet | 9. Acquisition LED |
| 5. Counter 1–4 | |

USB-C data

USB-C specifications		
	Connector type:	USB-C
	Function:	Data transfer

Tab. 10: USB-C specifications

USB-C PD IN

PD IN specifications		
	Connector type:	USB-C
	Function:	Power in

Tab. 11: PD IN specifications

CONNECTIONS AND PORTS

Power

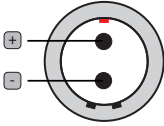
POWER specifications		
	Input <ul style="list-style-type: none"> – Rated input voltage – Input frequency – Power – Connector 	11...32 V _{DC} (max. 10...36 V _{DC}) DC 210 W 2-pin male LEMO HMJ.1B.302
	LED <ul style="list-style-type: none"> – Off – Green 	Power off Power on; independent from power source

Tab. 12: POWER specifications

Ethernet

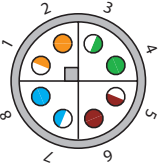
Ethernet specifications										
	Connector type:	8-pin female M12 x-coded								
	Pin assignment	<table border="0"> <tr> <td>1. DA+</td> <td>5. DD+</td> </tr> <tr> <td>2. DA-</td> <td>6. DD-</td> </tr> <tr> <td>3. DB+</td> <td>7. DC-</td> </tr> <tr> <td>4. DB-</td> <td>8. DC+</td> </tr> </table>	1. DA+	5. DD+	2. DA-	6. DD-	3. DB+	7. DC-	4. DB-	8. DC+
	1. DA+	5. DD+								
2. DA-	6. DD-									
3. DB+	7. DC-									
4. DB-	8. DC+									
LEDs <ul style="list-style-type: none"> – t.b.d. 										

Tab. 13: Ethernet specifications

Counter 1-4

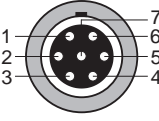
Counter specifications									
	Connector type:	7-pin female LEMO HEG.1B.307							
	Pin assignment:	<table border="0"> <tr> <td>1. Input A</td> <td>5. +5 V out</td> </tr> <tr> <td>2. Input B</td> <td>6. +12 V out</td> </tr> <tr> <td>3. Input Z</td> <td>7. GND signal</td> </tr> <tr> <td>4. GND power</td> <td></td> </tr> </table>	1. Input A	5. +5 V out	2. Input B	6. +12 V out	3. Input Z	7. GND signal	4. GND power
1. Input A	5. +5 V out								
2. Input B	6. +12 V out								
3. Input Z	7. GND signal								
4. GND power									

Tab. 14: Counter specifications

CONNECTIONS AND PORTS

Channels 1-8

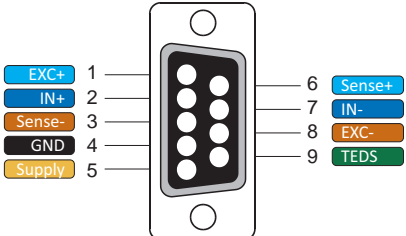
Channel specifications		Connector type:	9-pin female D-SUB	
	Connector type:	9-pin female D-SUB		
		Pin assignment:	1. +EXC 2. +IN 3. -Sense 4. GND 5. Supply	6. +Sense 7. -IN 8. -EXC 9. TEDS

Tab. 15: Channel specifications

DIO

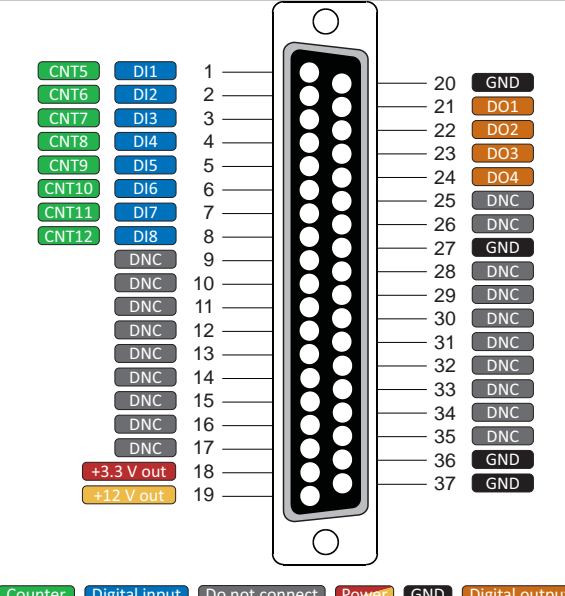
DIO specifications		Connector type:	37-pin female D-SUB		
	Connector type:	37-pin female D-SUB			
		Pin assignment:	1. DI1/CNT5 2. DI2/CNT6 3. DI3/CNT7 4. DI4/CNT8 5. DI5/CNT9 6. DI6/CNT10 7. DI7/CNT11 8. DI8/CNT12 9. DNC 10. DNC 11. DNC 12. DNC 13. DNC 14. DNC 15. DNC 16. DNC 17. DNC 18. +3.3 V out 19. +12 V out 20. DO1 21. DO2 22. DO3 23. DO4 24. DO4 25. DNC 26. DNC 27. GND 28. DNC 29. DNC 30. DNC 31. DNC 32. DNC 33. DNC 34. DNC 35. DNC 36. GND 37. GND	14. DNC 15. DNC 16. DNC 17. DNC 18. +3.3 V out 19. +12 V out 20. GND 21. DO1 22. DO2 23. DO3 24. DO4 25. DNC 26. DNC	27. GND 28. DNC 29. DNC 30. DNC 31. DNC 32. DNC 33. DNC 34. DNC 35. DNC 36. GND 37. GND

Tab. 16: DIO specifications

CAN 1-2

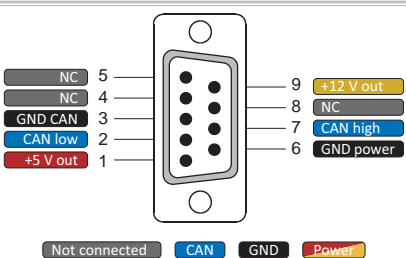
CAN specifications		Connector type:	9-pin male D-SUB	
	Connector type:	9-pin male D-SUB		
		Pin assignment:	1. +5 V out 2. CAN low 3. GND CAN 4. NC 5. NC	6. GND power 7. CAN high 8. NC 9. +12 V out

Tab. 17: CAN specifications

Acquisition LED

The following table gives an overview of the different types of LED lighting.

Color	Description	Comment
Static green	Ready	-
Fading green	Preparing acquisition and network interface	During firmware updating process
Flashing green	Recording	-
Fading orange	Booting	-

Tab. 18: Acquisition LED

SIGNAL CONNECTION

Signal connection

Direct signal connection

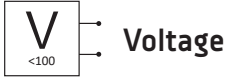

Analog input

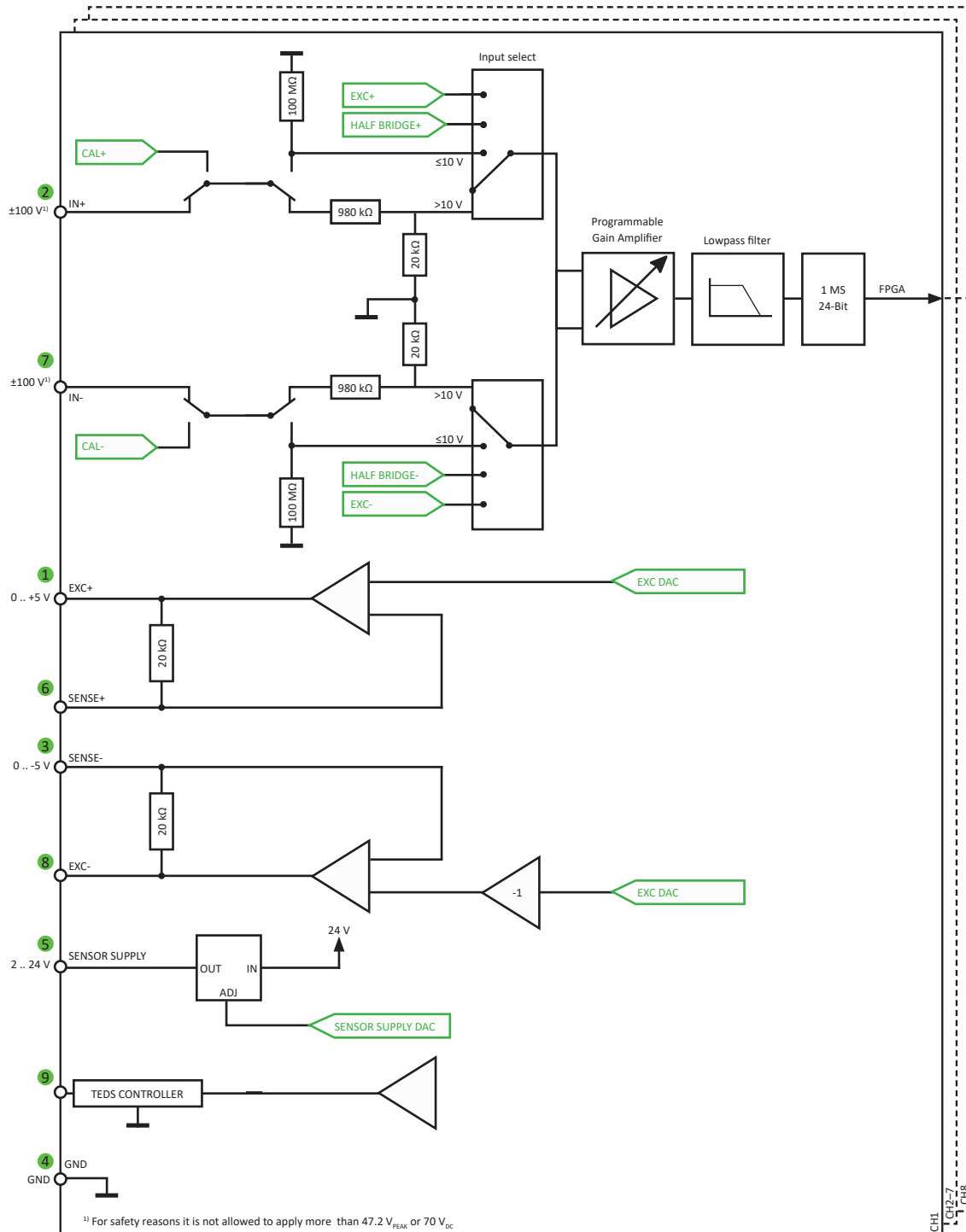

SIGNAL CONNECTION

Voltage measurement

NOTICE

Module is not isolated. Do not exceed ± 12.5 V common mode range.

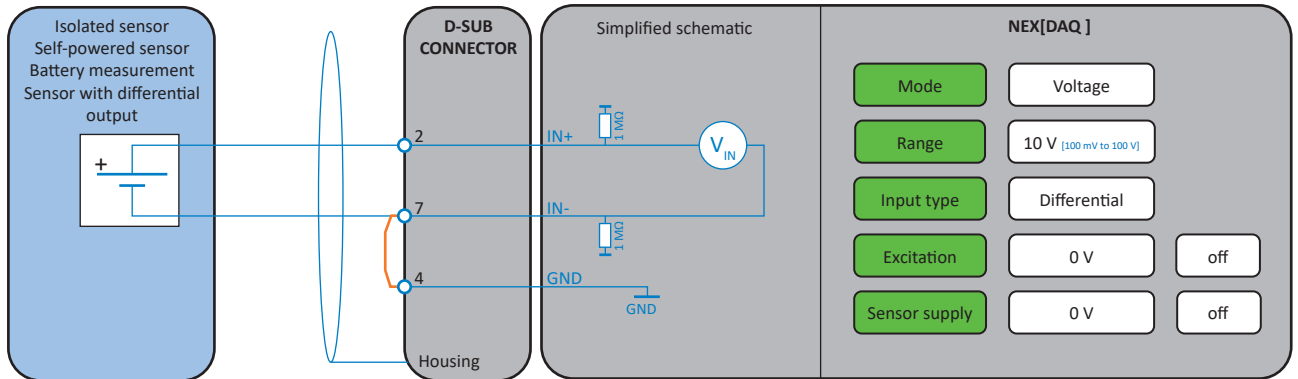

External solder bridge

Optional: ADAP-DIFF-D9M-BNCF adapter.



Adapter with integrated 100 kΩ resistor from IN- to GND for direct BNC connection.

Voltage measurement with D-SUB to BNC adapter

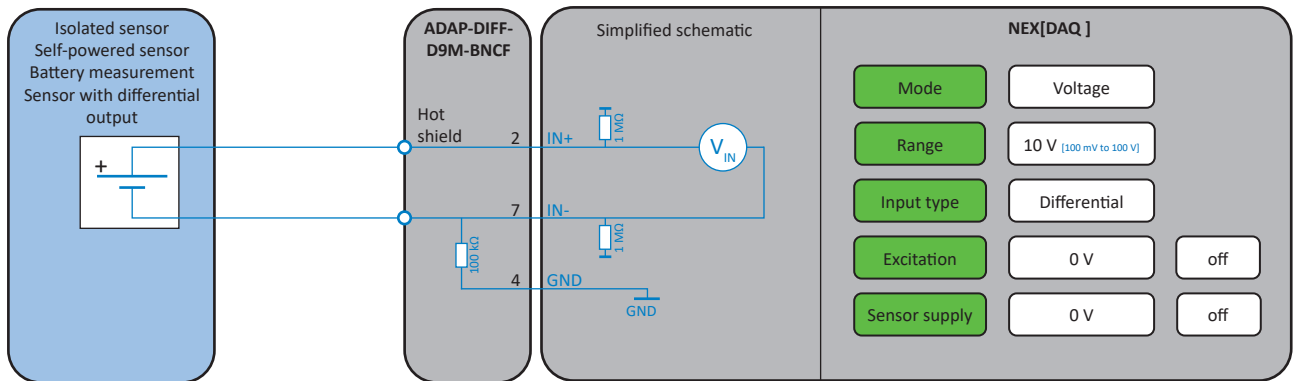

Differential output sensor with sensor supply

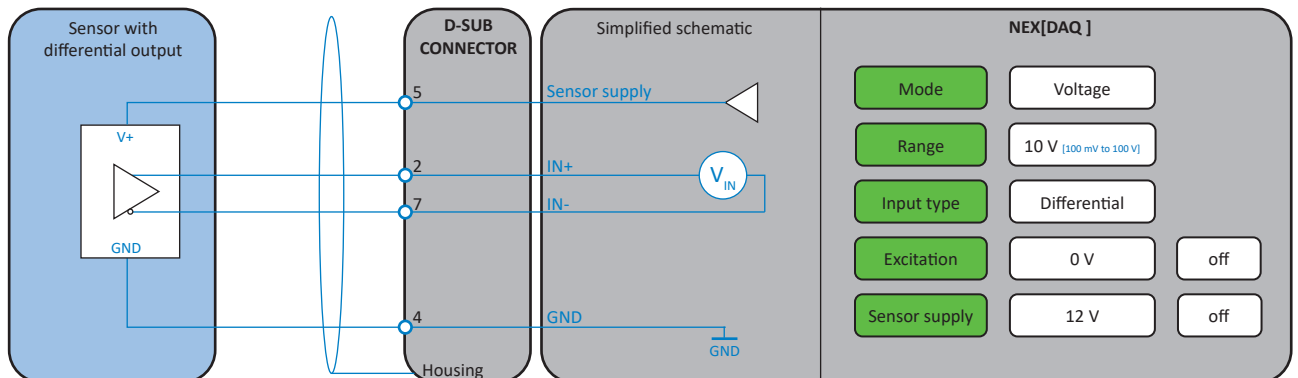

SIGNAL CONNECTION

NOTICE

Input voltage must not exceed maximum common mode voltage.

Single-ended sensor with sensor supply

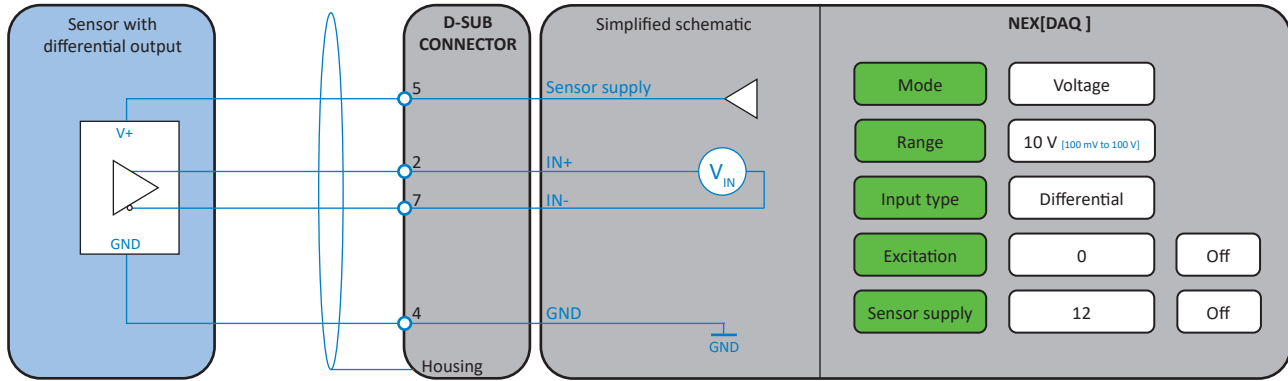

NOTICE

Input voltage must not exceed maximum common mode voltage.

Single-ended sensor with bipolar sensor supply

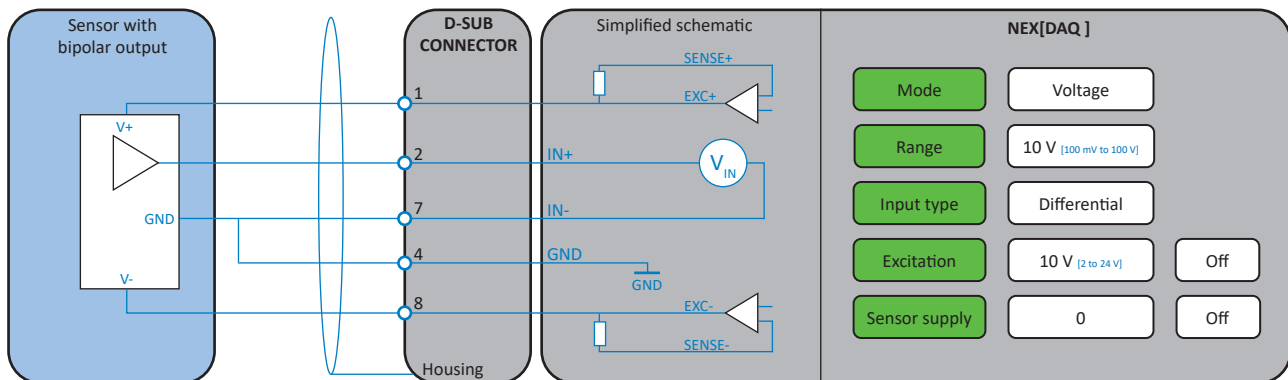

Full bridge 6-wire

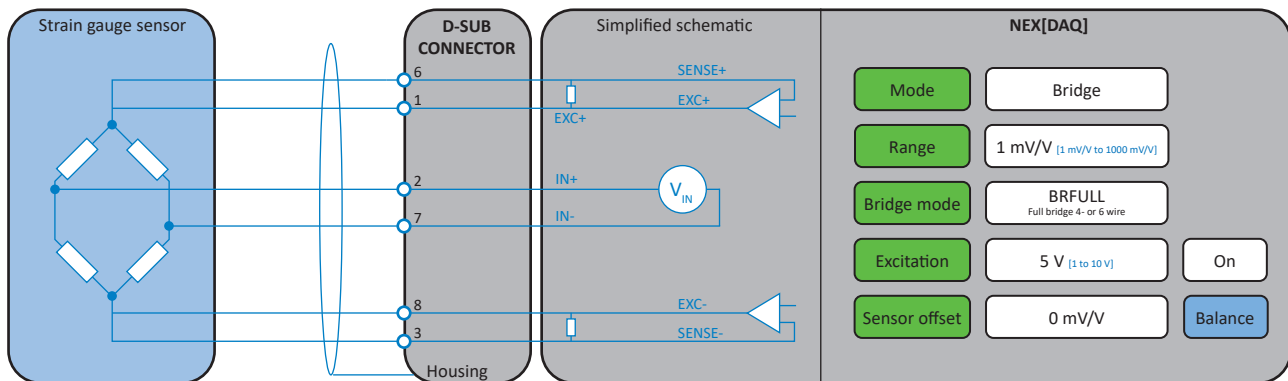

SIGNAL CONNECTION

Full bridge 4-wire

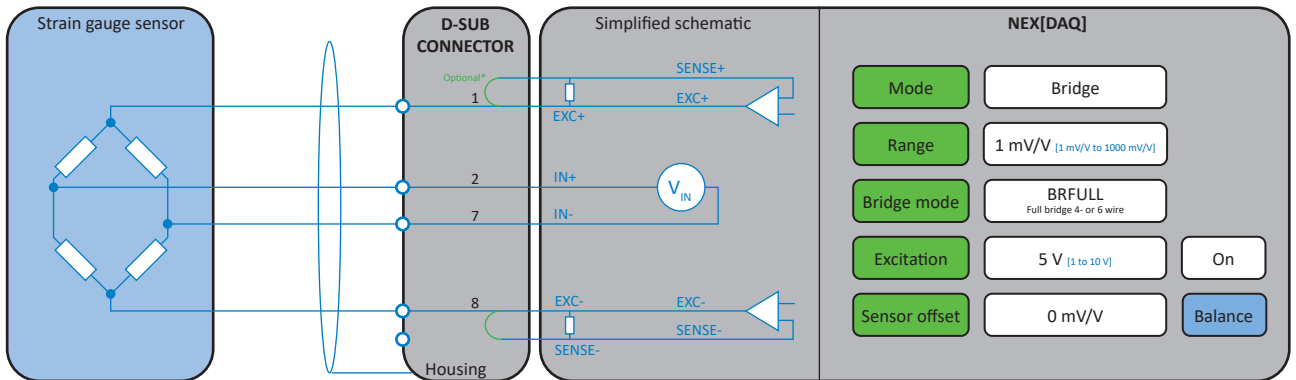

Half bridge 5-wire

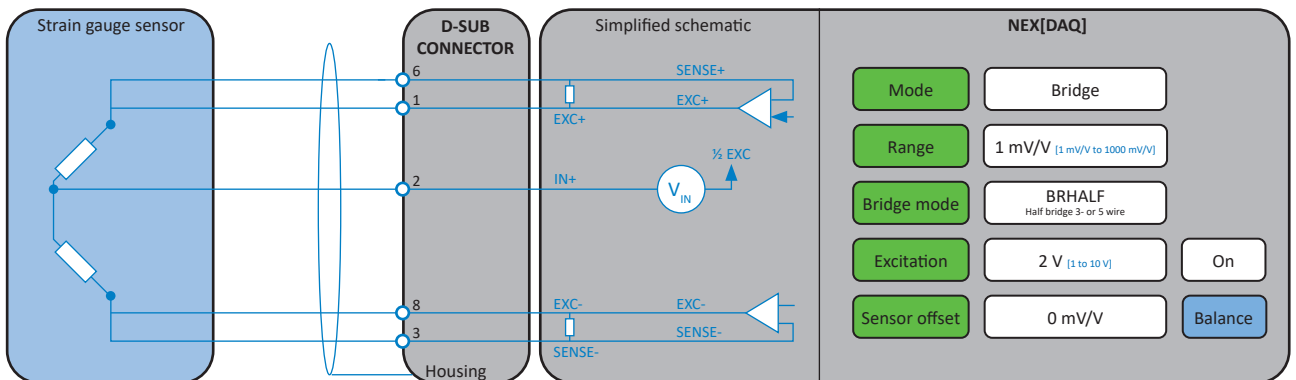

Half bridge 3-wire

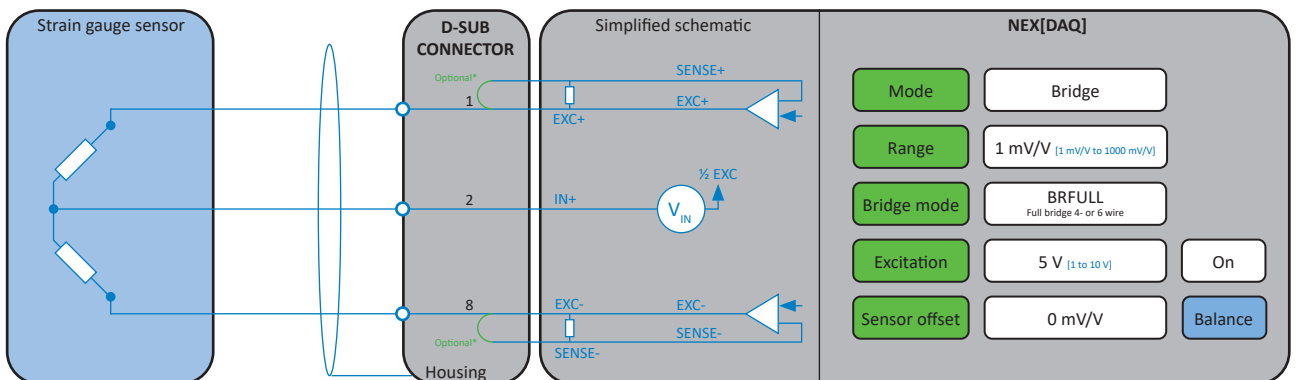

SIGNAL CONNECTION

Potentiometer

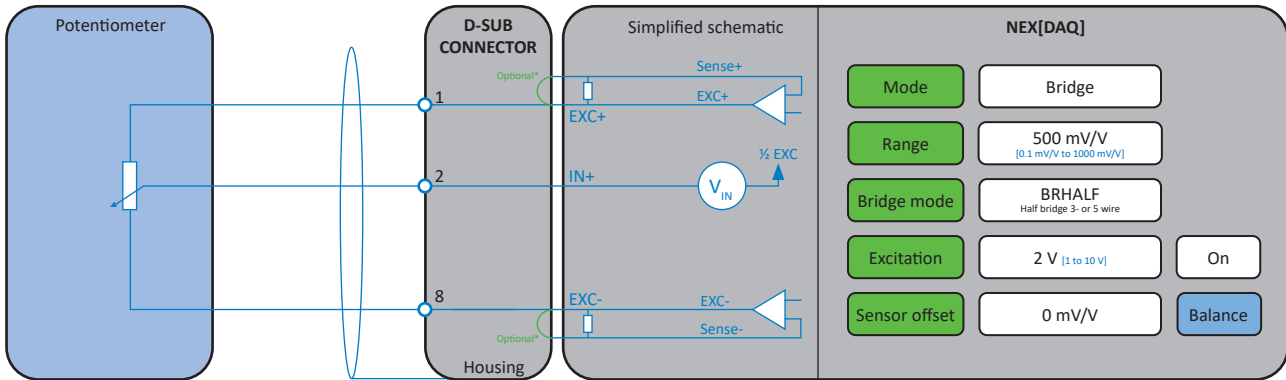

INFORMATION

*Optional: Might be installed on existing sensor cables from previous amplifier series.

Cables and shielding

To suppress electromagnetic interference as much as possible, cables with shielded twisted pairs are recommended. Connect the shield to the connector housing or to the conductive mechanical structure.

The twisted pairs for **full bridge**, **half bridge**, **voltage** and **resistance** mode are:

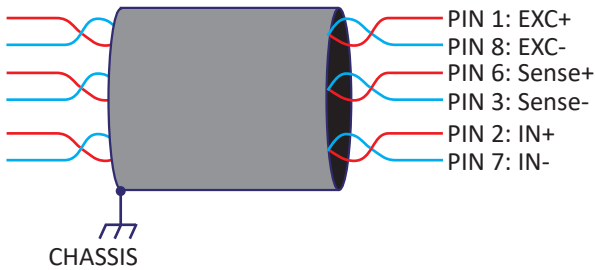

Fig. 4: Cables and shielding

Shielding/noise reduction

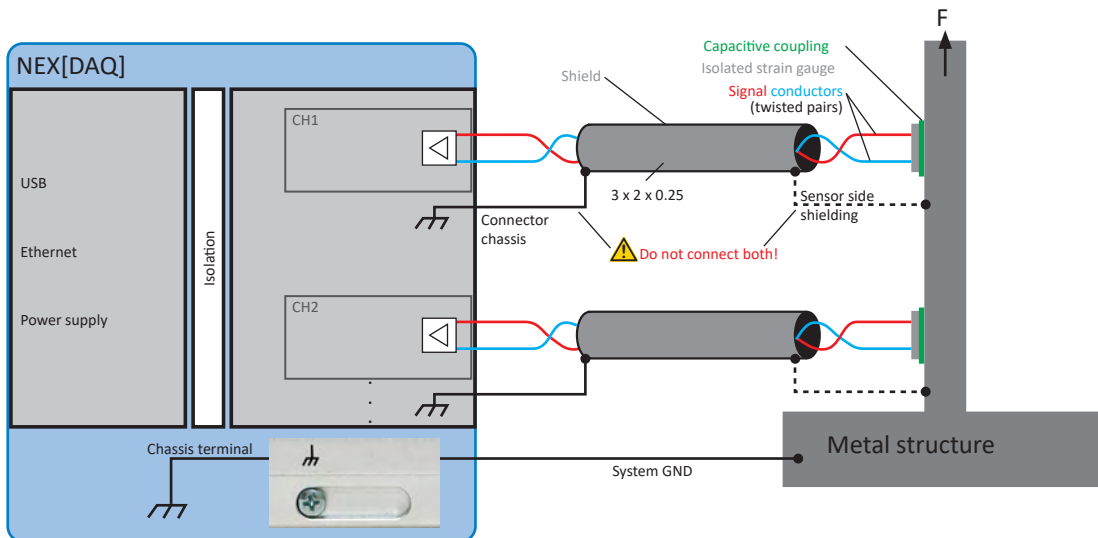

Fig. 5: Strain gauge measurement on a metal structure

INFORMATION

Connect the cable shield either to the connector chassis on the TRION side or to the structure on the sensor side. Do **NOT** connect on both sides.

It is crucial that you connect your DEWETRON system ground (chassis terminal) to the ground potential of your measured object, e.g. via a connection to the metal structure of your proving ground or to the car's chassis. This guarantees that the measurement system is not floating against the measured structure. Only if the DEWETRON system and the measured structure have an earth connection the system grounding line might not be needed.

Digital input DI1-DI8 | CNT (A, B, Z)

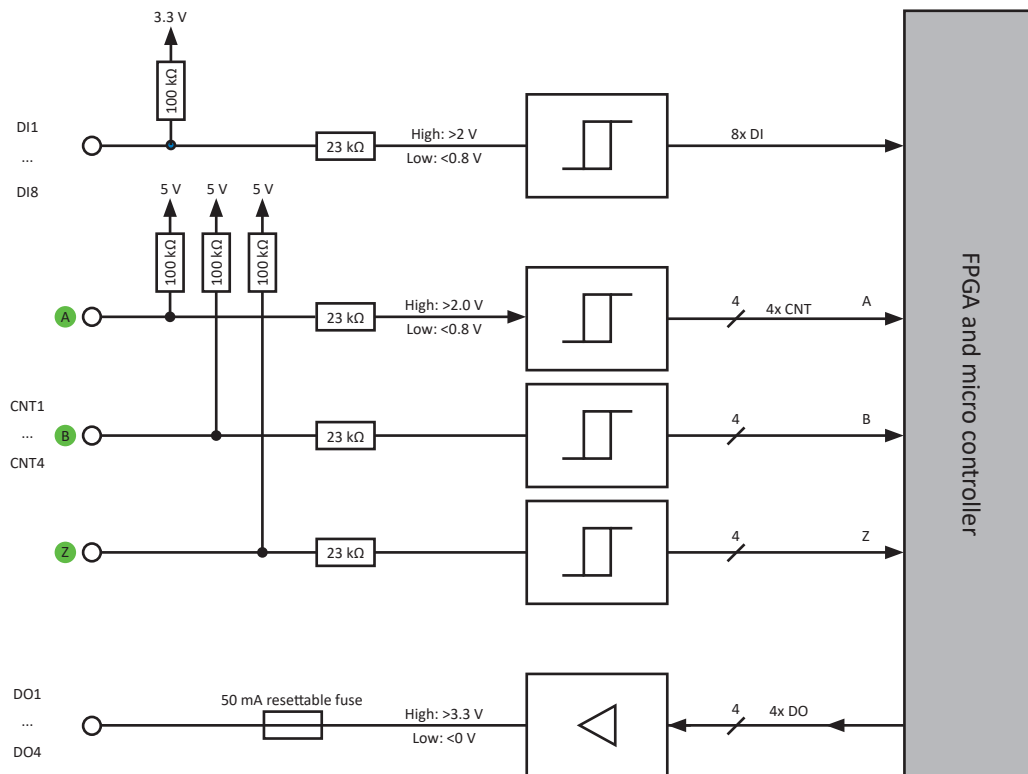

SIGNAL CONNECTION

Counter input

Encoder, up-down counter

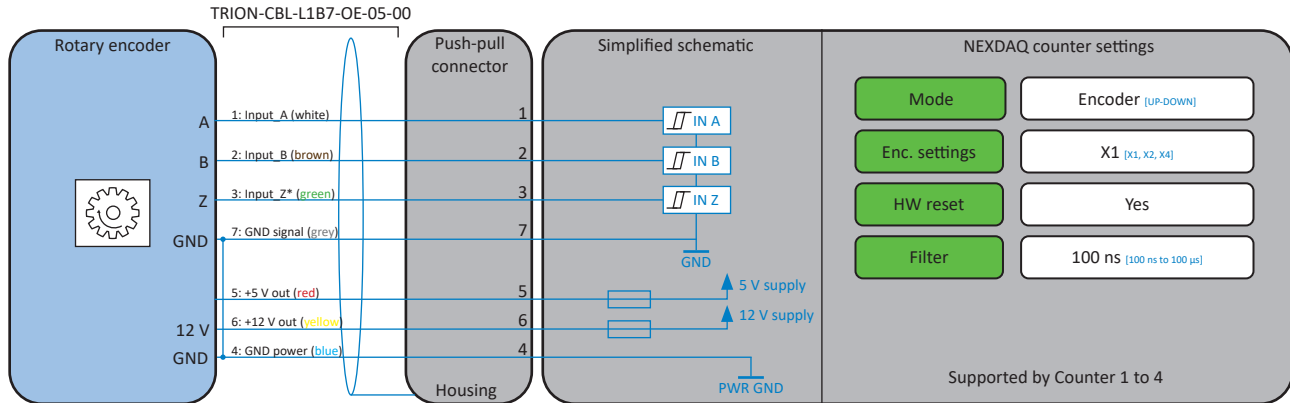

*Input_Z is optional. This input is for the zero pulse. It is high once per revolution. It is used to indicate the 0° position when HW reset is active.

Optional accessory

TRION-CBL-L1B7-OE-05-00: High-quality cable from LEMO 1B.307 plug to open end, 5 m for TRION-CNT-6-LEMO modules.

Gated event counting, two-pulse edge separation

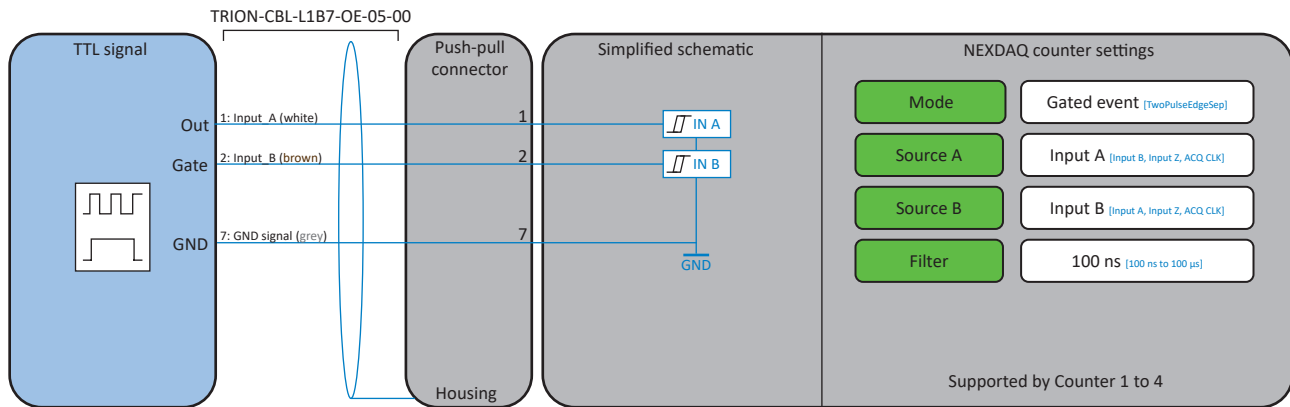

Event counting, pulse-width measurement, frequency measurement

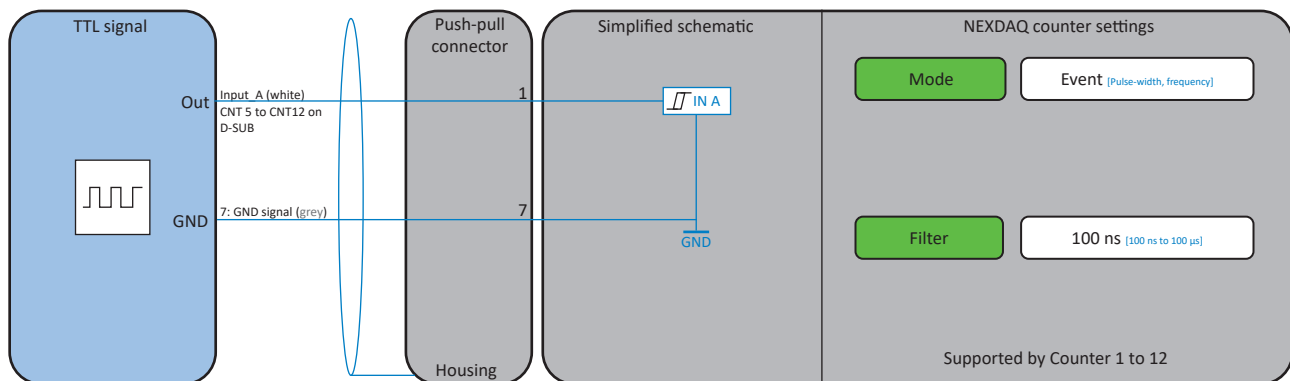

CAN input

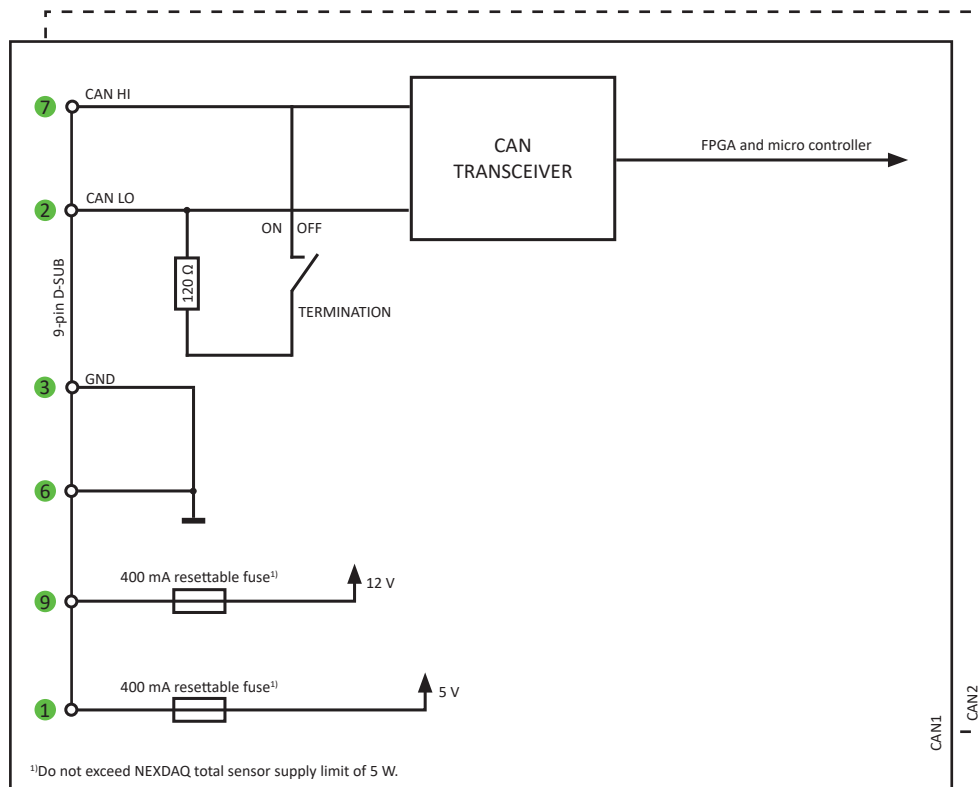

Connect XR series modules to NEX[DAQ]

By connecting XR series modules to one of the two CAN ports, the NEX[DAQ] can easily be expanded to include static channels such as temperature.



Fig. 6: NEX[DAQ] with 2 XR modules connected

Up to 4 XR series modules can be supplied directly from the NEXDAQ. Note that the maximum supply limit of 5 W must be taken into account for the supply of the XR modules.

To learn more about the XR series and how to connect them, refer to the corresponding manual available at <https://ccc.dewetron.com/dl/manual-xr-series>.

SIGNAL CONNECTION

For the use of multiple modules, a separate power supply unit is required.

▶ CPAD-CBL-LD9-2



2 m adapter cable to connect CPAD/XR series modules to the NEXDAQ CAN interface;
LEMO FGG.1B.304 plug to a D-SUB-9 socket

Signal connection via MSI



MSI2-V-600



High-voltage measurement

MSI2-V-600				
Sensor connection		4 mm safety banana sockets		
Input attenuation		250 ±0.5 %		
Input type		Differential		
Rated input voltage to earth according to IEC/EN 61010-2-30		300 V CAT III / 600 V CAT II		
Common mode voltage		±1000 V		
Overvoltage protection		1500 V _{PEAK} / 1000 V _{RMS} (1 min)		
Input impedance		5 MΩ differential / 2.5 MΩ to earth		
Gain drift		Typ. 25 ppm/K (max. 40 ppm/K)		
Input offset drift		200 μV/K		
Bandwidth (-3 dB)		60 kHz		
TEDS		For adapter identification and calibration data		
Ranges		±1000 V; ±500 V; ±200 V; ±100 V		
Accuracy	DC to 1 kHz	±0.1 % of reading ±100 mV		
	>1 kHz to 5 kHz	±0.5 % of reading ±100 mV		
	>5 kHz to 10 kHz	±1 % of reading ±100 mV		
Signal-to-noise ratio; spurious-free SNR				
Effective number of bits; noise mV _{pp}		SNR	SFDR	ENOB
Sample rate		[dB]	[dB]	[Bit]
5 kS/s		102	130	16.7
10 kS/s		99	127	16.2
20 kS/s		96	122	15.7
50 kS/s		92	119	15.0
100 kS/s		89	117	14.6
200 kS/s		87	113	14.1
Typical CMRR		74 dB @ 100 Hz		
		50 dB @ 10 kHz		

Tab. 19: Signal connection MSI2-V-600

SIGNAL CONNECTION

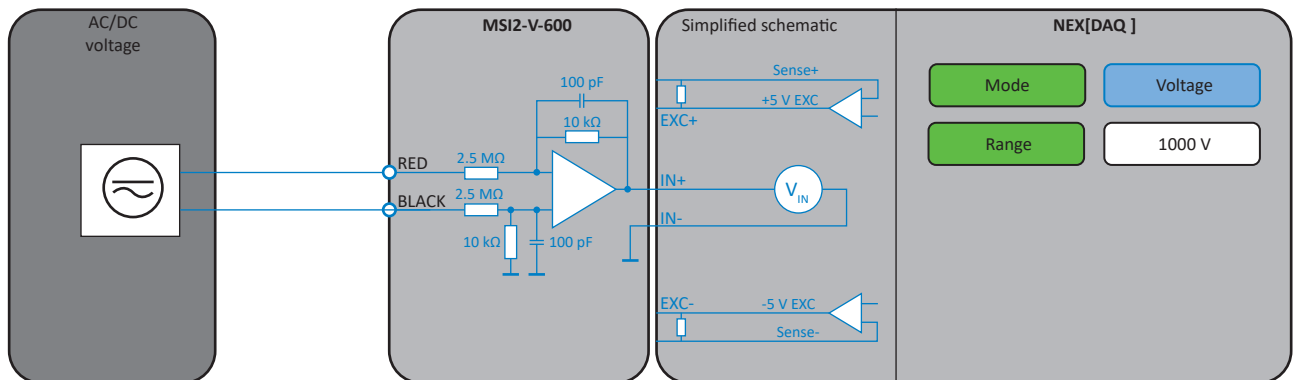

CAUTION



Risk of injury

Voltage measurement up to 600 V_{RMS} must only be carried out with safety banana plug cords.



MSI2-STG

Strain gauge measurement

- ▶ Full, half or quarter bridge
- ▶ 5 V or 10 V excitation with remote sense
- ▶ 120 and 350 Ω quarter bridge
- ▶ Simple connection without soldering



MSI2-STG				
Input range	20 mV/V at 5V excitation			
Sensor excitation voltage ¹⁾	5 V or 10 V (±5 V); remote sense support			
Maximum current	40 mA per channel			
Protection	Continuous short to ground; short circuit limit is 70 mA			
Supported bridge-types	Full bridge 4 or 6 wire Half bridge 3 or 5 wire Quarter bridge 3 wire; 120 Ω and 350 Ω bridge completion			
DC accuracy	±0.2 % of reading ±5 μV/V			
Bandwidth (-3 dB)	60 kHz			
Signal-to-noise ratio; spurious-free SNR	20 mV/V range			
Effective number of bits; noise mV _{pp}	SNR	SFDR	ENOB	Noise_{pp}
Sample rate	[dB]	[dB]	[Bit]	[mV _{pp}]
5 kS/s	101	124	17.1	0.88
10 kS/s	98	125	16.6	1.4

Tab. 20: Signal connection MSI2-STG

SIGNAL CONNECTION

MSI2-STG					
	20 kS/s	83	123	14.1	1.9
	50 kS/s	79	120	13.5	3.3
	100 kS/s	76	115	13.0	4.5
	200 kS/s	73	110	12.5	7
Drift	Offset: 0.4 $\mu\text{V}/^\circ\text{C}$; gain: max. 50 ppm/ $^\circ\text{C}$				
Sensor connection	Push-in spring connection; 0.14 to 0.5 mm ² ; AWG 26 to 20				
TEDS	For adapter identification and calibration data				

Tab. 20: Signal connection MSI2-STG

1) Excitation is fixed when MSI is connected.

The MSI2-STG is designed to connect nearly every strain gauge sensor to the NEX[DAQ].

Various bridge-types can be configured by jumper. That makes it very flexible and an ideal solution for strain gauge measurement on fixed installations.

It is also a perfect solution for harsh electronic environment. Because this tiny amplifier can be mounted directly next to the sensor with very short cables in between. The signal is immediately amplified by a factor of 50. This reduces the impact of electromagnetic disturbances by the same factor. The maximum cable length between MSI and the NEX[DAQ] is 50 meters.

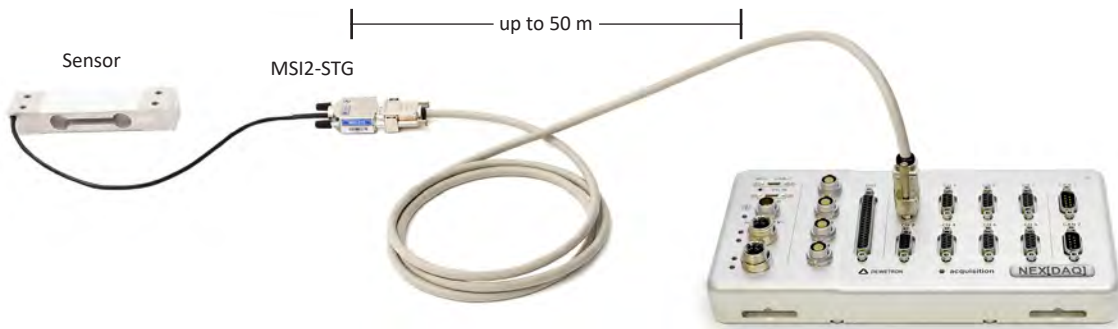

Fig. 7: MSI2-STG cable length

Jumper settings

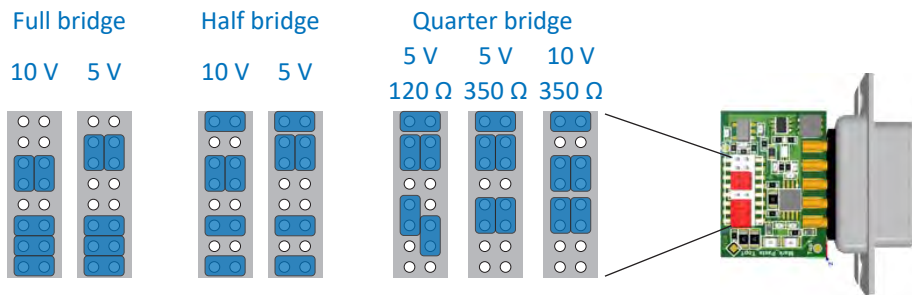

Fig. 8: Jumper settings

Connecting a sensor

In order to connect a sensor proceed as follows:

1. Check the sensor datasheet and determine the correct connection.



2. Prepare the sensor cable.



3. Connect the cable to the PCB.

The shield must be placed between housing and plastic.

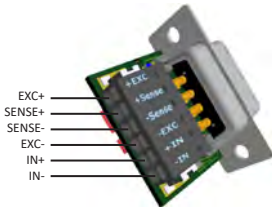

4. Apply the jumper according to the sensor.



5. Close the housing.



6. Connect the sensor directly or via extension cable.



7. MS12-STG is detected automatically. Sensor scaling can be applied.

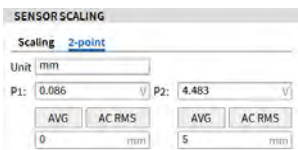

The sensor is now connected.

SIGNAL CONNECTION

Full bridge 6-wire

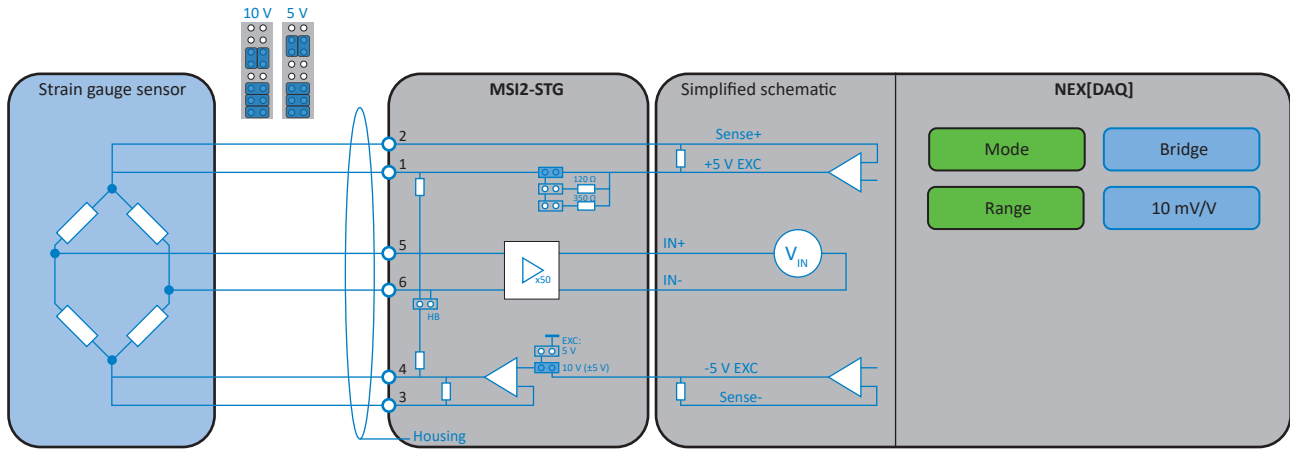

INFORMATION Full-bridge can also be connected directly..

Full bridge 4-wire

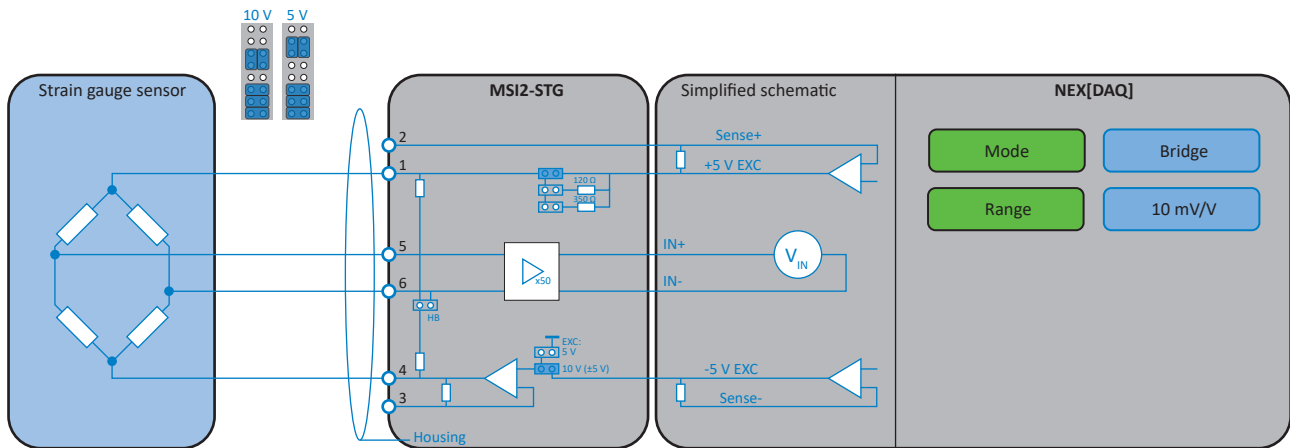

Half bridge 3-wire

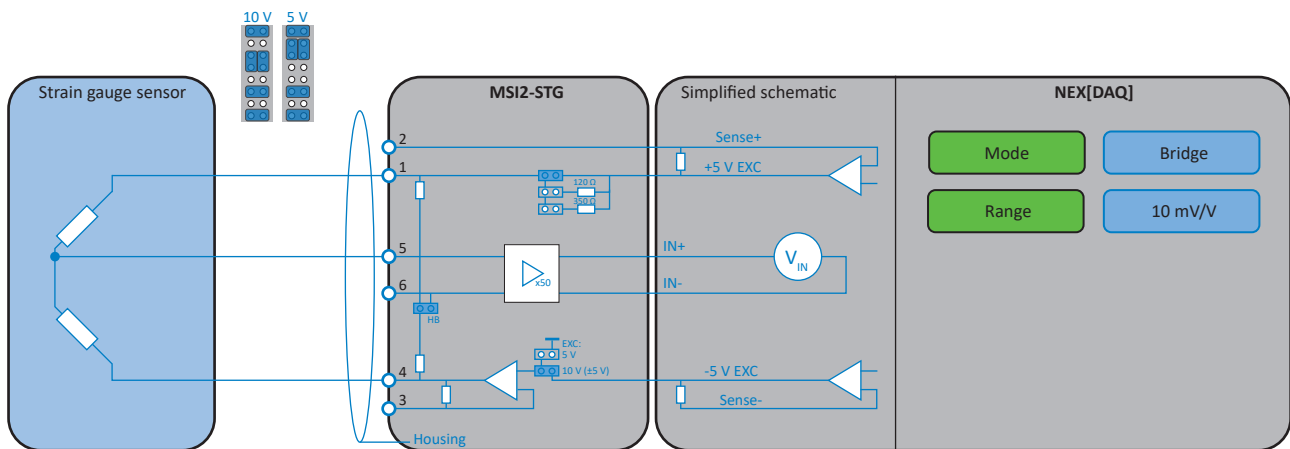

SIGNAL CONNECTION

Quarter bridge 3-wire

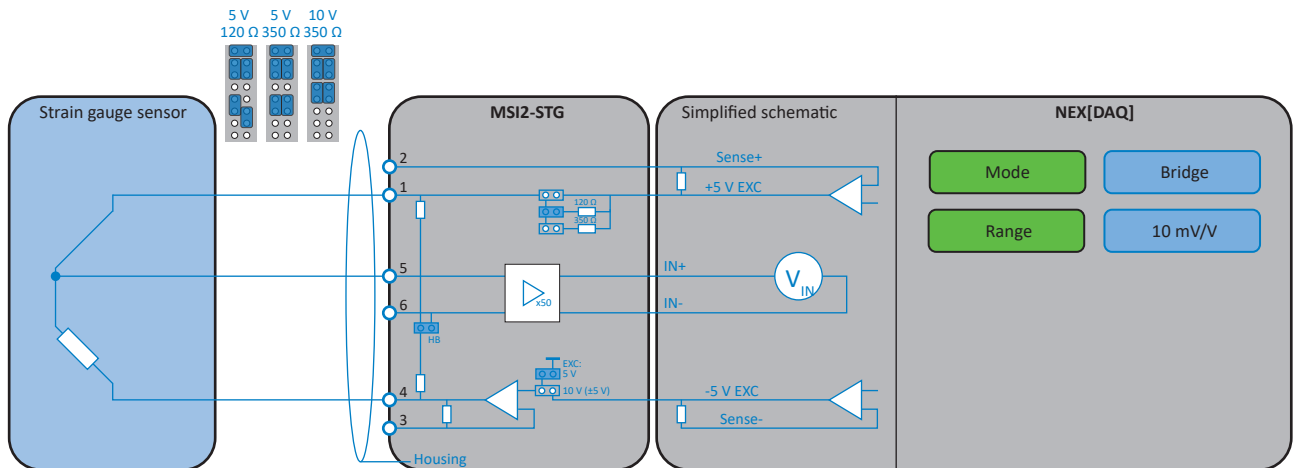

IEPE®

MSI-BR-ACC



MSI-BR-ACC				
Input range	±10 V			
Sensor excitation	4 mA ±10 %			
Compliance voltage	>23 V			
Accuracy	30 Hz to 30 kHz: 0.2 %			
Power consumption	Max. 380 mW			
Input coupling	AC 1.4 Hz			
Bandwidth	250 kHz			
Signal-to-noise ratio; spurious-free SNR				
Effective number of bits; noise mV_{pp}	SNR	SFDR	ENOB	Noise_{pp}
Sample rate	[dB]	[dB]	[Bit]	[mV_{pp}]
5 kS/s	101	124	17.1	0.88
10 kS/s	98	125	16.6	1.4
20 kS/s	83	123	14.1	1.9
50 kS/s	79	120	13.5	3.3
100 kS/s	76	115	13.0	4.5
200 kS/s	73	110	12.5	7
Sensor connection	BNC			
TEDS	For adapter identification			

Tab. 21: Signal connection MSI-BR-ACC

SIGNAL CONNECTION

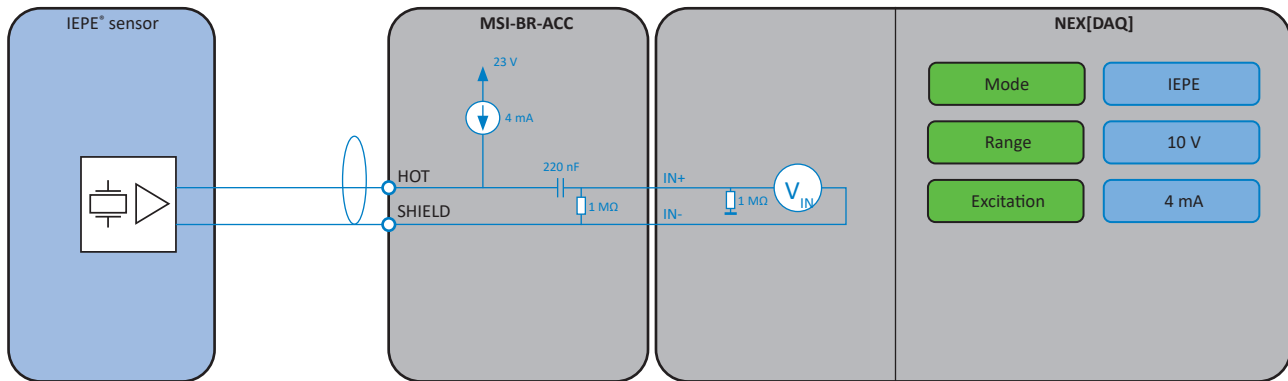

MSI2-CH-x				
Input range				
– MSI2-CH-5	±5000 pC			
– MSI2-CH-100	±100 000 pC			
Accuracy	3 Hz to 30 kHz: 0.5 %			
Gain drift	50 ppm/°C			
Input coupling	AC 0.14 Hz			
Bandwidth	250 kHz			
Signal-to-noise ratio; spurious-free SNR				
Effective number of bits; noise mV_{pp}	SNR	SFDR	ENOB	Noise_{pp}
Sample rate	[dB]	[dB]	[Bit]	[pC _{pp}]
10 kS/s	101	130	17.1	0.24
20 kS/s	99	130	16.7	0.35
50 kS/s	95	125	16.0	0.55
100 kS/s	92	120	15.5	0.8
200 kS/s	89	115	15.1	1.15
Sensor connection	BNC			
TEDS	For adapter identification and calibration data			

Tab. 22: Signal connection MSI2-CH-x

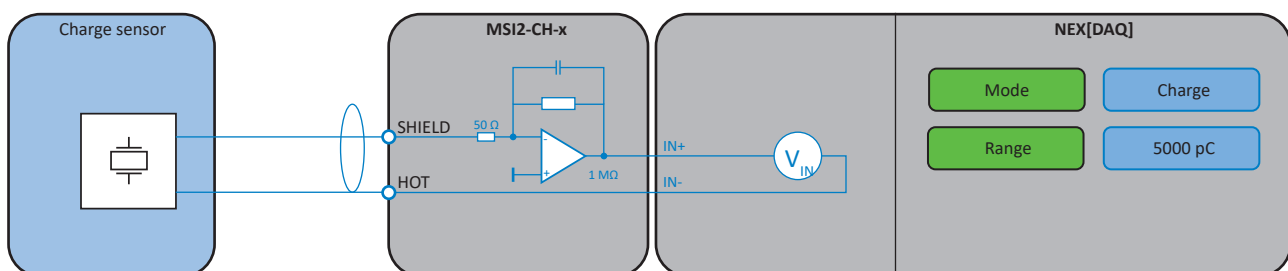

NOTICE

The MSI-CH-x input is very sensitive to electrostatic discharge and to floating voltages. To avoid damage, the unit under test and the housing of the DEWETRON measuring system must be grounded.

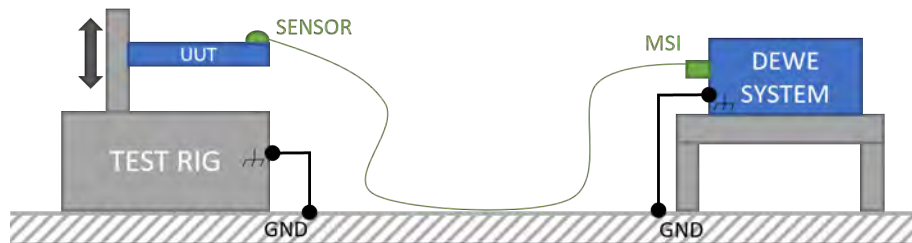

Thermocouple



MSI2-TH-x	
Thermocouple types	Type K, J, T, C
Sensor connection	1 m cable with standard miniature thermocouple connector according to TC type
Preamplifier	Integrated; cable drive capability 50 m
Open thermocouple detection	100 M Ω pullup; broken sensor shows positive full scale
CJC accuracy	1.0 $^{\circ}$ C
Input impedance	>10 Ω
Bias current	50 nA
Linearization	Through software according to sensor type
Bandwidth	130 kHz
Isolation	
– Use with TRION-1802-dLV	Not isolated
– Use with TRION-MULTI series	350 V
Typical peak to peak noise for sensor type K	
– 1 kHz bandwidth	0.50 $^{\circ}$ C
– 100 Hz bandwidth	0.25 $^{\circ}$ C
– 10 Hz bandwidth	0.04 $^{\circ}$ C
TEDS	For adapter identification and calibration data

Tab. 23: Signal connection MSI2-TH-x

SIGNAL CONNECTION

Accuracy incl. CJC error	
MSI2-TH-K – Type K (DIN-EN 60584-1)	
Input ranges	-200 to 1370 °C (-328 to 2498 °F)
Accuracy incl. CJC error	5 -200 to -100 °C ±1.2 °C
	-100 to 1370 °C ±0.6 °C
MSI2-TH-J – Type J (DIN-EN 60584-1)	
Input ranges	-210 to 1200 °C [-346 to 2192 °F]
Accuracy incl. CJC error	-200 to -100 °C ±1.1 °C
	-100 to 1200 °C ±0.6 °C
MSI2-TH-T – Type T (DIN-EN 60584-1)	
Input ranges	-270 to 400 °C [-454 to 752 °F]
Accuracy incl. CJC error	-250 to -100 °C ±3 °C
	-100 to 400 °C ±0.8 °C
MSI2-TH-C – Type C (ASTM E988-96)	
Input ranges	0 to 2300 °C [32 to 4172 °F]
Accuracy incl. CJC error	0 to 1600 °C ±1 °C
	1600 to 2300 °C ±1.5 °C

Tab. 24: Accuracy incl. CJC error

Functional description

The MSI2-TH-x series is the improved version of the previous MSI series. The accuracy is approximately 3 times higher than at the previous version. A calibrated high precision cold junction compensation is included in the adapter. It comes with an integrated preamplifier that boosts the tiny thermocouple voltage up to a few volts. That is why the V2 series can be directly placed next to the sensor. Use extension cables up to 50 m between the MSI and the TRION system instead of having long thermocouple lines with small signal level. That can greatly improve your signal quality in a harsh electronic environment.

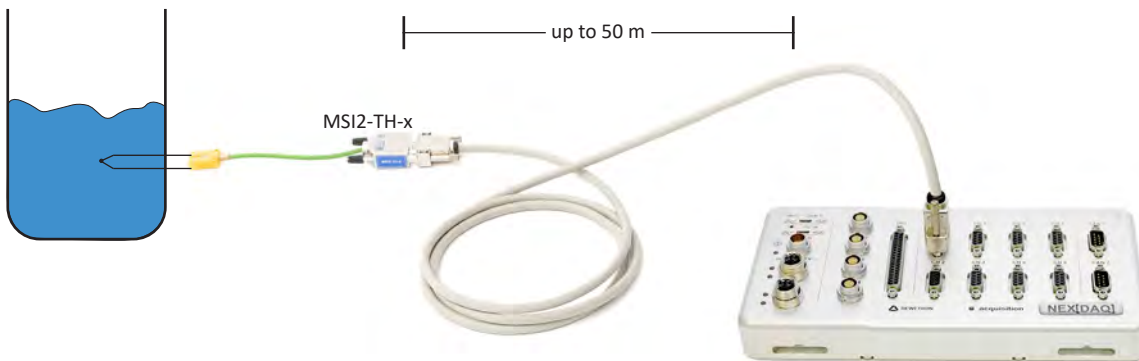
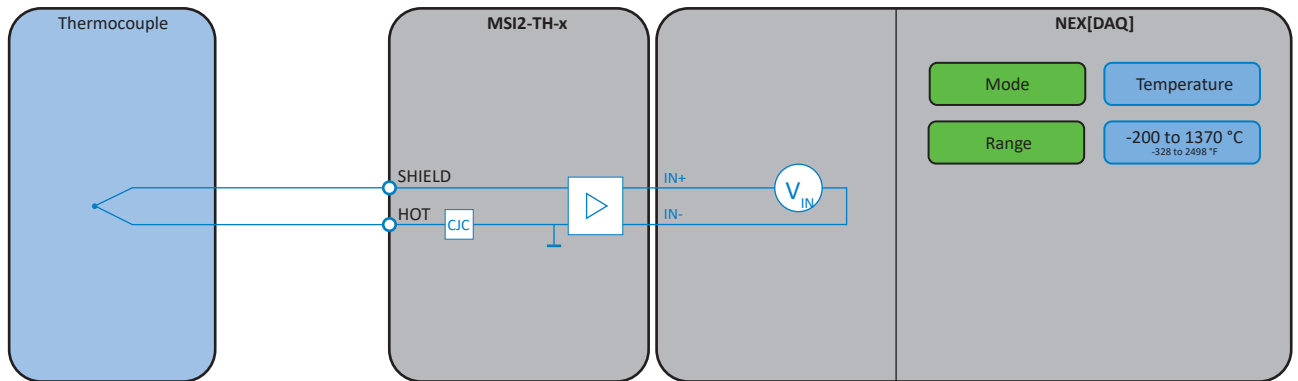

Fig. 9: Functional description MSI2-TH-x

SIGNAL CONNECTION



MSI-BR-RTD

RTD

- ▶ Support of Pt100, Pt200, Pt500, Pt1000, Pt2000
- ▶ 2-, 3- or 4 wire connection



MSI-BR-RTD	
Supported sensors	Resistance, Pt100, Pt200, Pt500, Pt1000, Pt2000
Temperature range	-200 °C to 850 °C
Constant current	1.25 mA
Constant current accuracy	±0.02 % from calibrated value
Constant current drift	22 ppm/ °C
Linearization	Through software according to sensor type
Connection types	2-, 3- or 4-wire
Isolation	
– Use with TRION-1802-dLV	Not isolated
– Use with TRION-MULTI series	350 V
Typical peak to peak noise for Pt100	
– 1 kHz bandwidth	0.25 °C
– 100 Hz bandwidth	0.08 °C
– 10 Hz bandwidth	0.02 °C
Sensor connection	5-pin BINDER connector series 712
TEDS	For adapter identification and calibration data

Tab. 25: Signal connection MSI-BR-RTD

SIGNAL CONNECTION

Accuracy		
Type	Range	Accuracy
Pt100 (DIN EN 60751)	-200 to 850 °C	0.05 % of reading ±0.65 °C
Pt200 (DIN EN 60751)	-200 to 850 °C	0.05 % of reading ±0.36 °C
Pt500 (DIN EN 60751)	-200 to 850 °C	0.04 % of reading ±0.17 °C
Pt1000 (DIN EN 60751)	-200 to 850 °C	0.04 % of reading ±0.11 °C
Pt2000 (DIN EN 60751)	-200 to 260 °C	0.04 % of reading ±0.10 °C

Tab. 26: Accuracy MSI-BR-RTD

Sensor connector

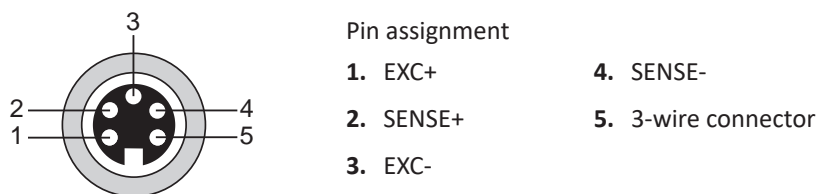
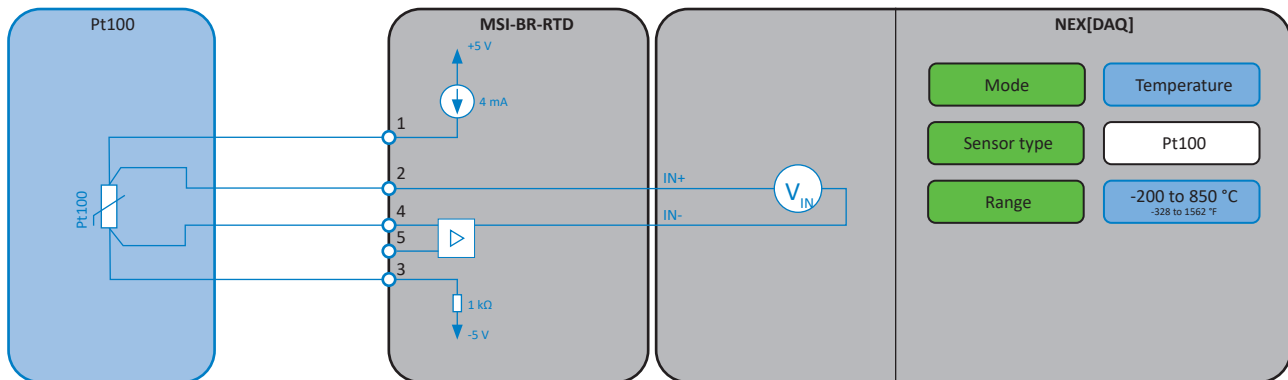
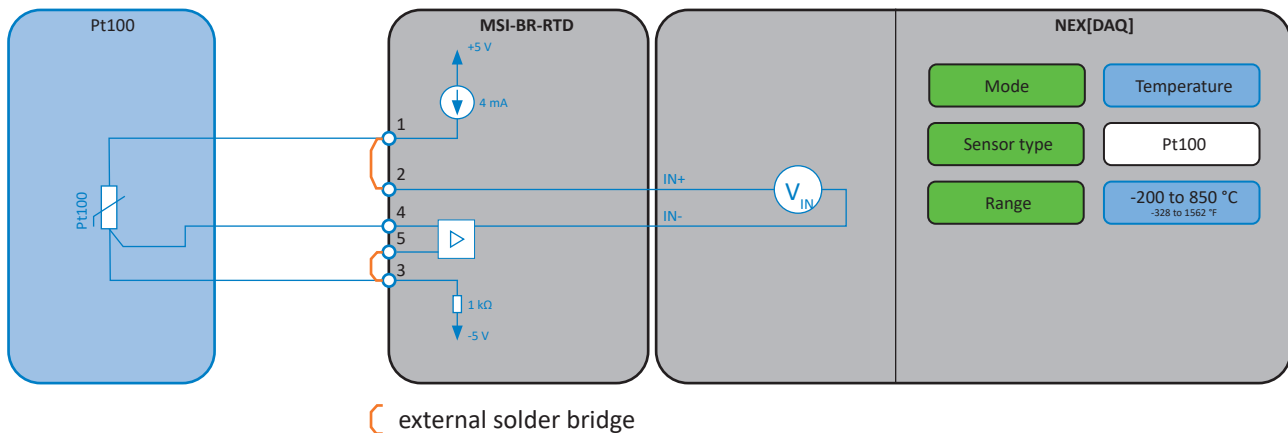

Fig. 10: Sensor connection MSI-BR-RTD

RTD 4-wire sensor



RTD 3-wire sensor



SIGNAL CONNECTION

RTD 2-wire sensor

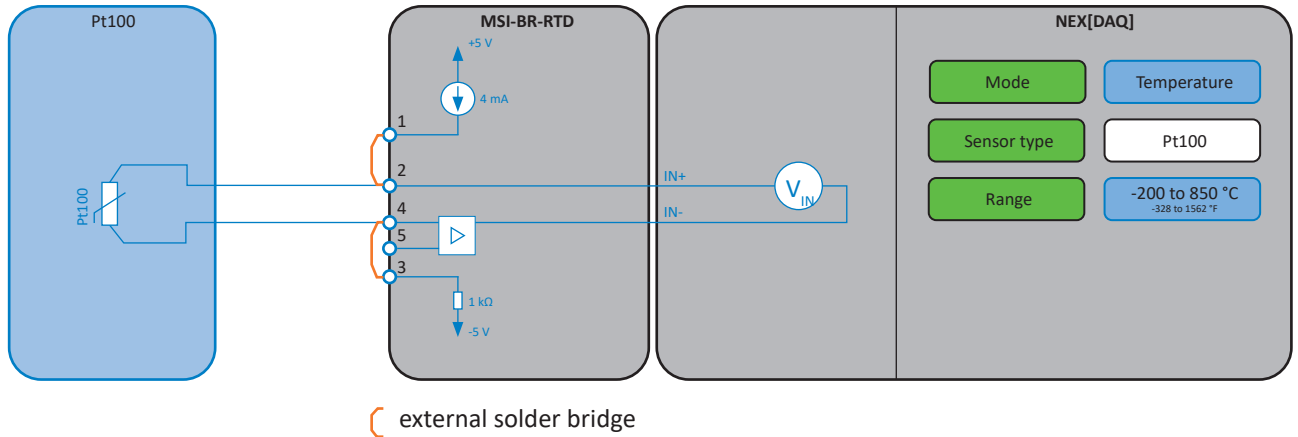

LVDT



MSI2-LVDT	
Transducer type	LVDT with 5 or 6 electrical connections (wires)
Sensor connection	Soldering
Excitation voltage	3 V _{RMS}
Excitation frequency	2.5 kHz, 5 kHz, 18 kHz selectable by jumper (H, M, L; ±5 %)
Output at stroke ends	280 mV/V to 1666 mV/V at full scale (±5 V), adjustable by gain-potentiometer

Tab. 27: Signal connection MSI2-LVDT

Functional description

The MSI2-LVDT is a high reliability conditioner for measurement of displacement with an LVDT (Linear Variable Differential Transformer). It can be used with 5- or 6-wire transducers.

The MSI2-LVDT provides the sine wave sensor excitation and converts the sensor output into a linear voltage output. With the gain potentiometer the MSI2-LVDT can be adjusted to a measuring range from 280 mV/V to 1666 mV/V. This allows a rough adjustment to the sensor. The best way is to bring the sensor to the end position and adjust the output to about 4.5 V. The exact adjustment of the sensor should be done by two point scaling in the software.

Thereby the MSI2-LVDT sensitivity is equivalent to 5 V/stroke end length (in mm or inch) [V/mm(inch)]. Once that is done apply the strain relief brackets and close the MSI.

SIGNAL CONNECTION

Sensor connector

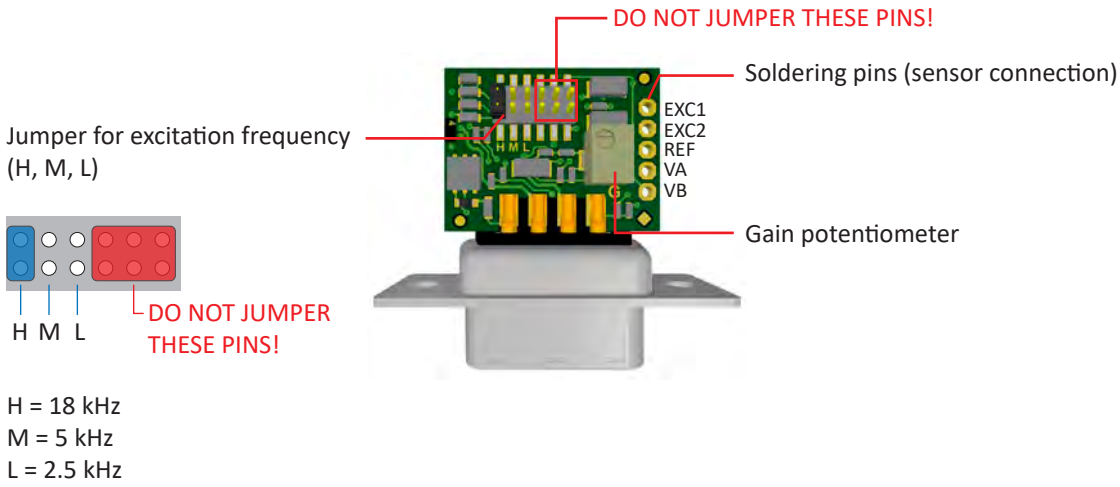
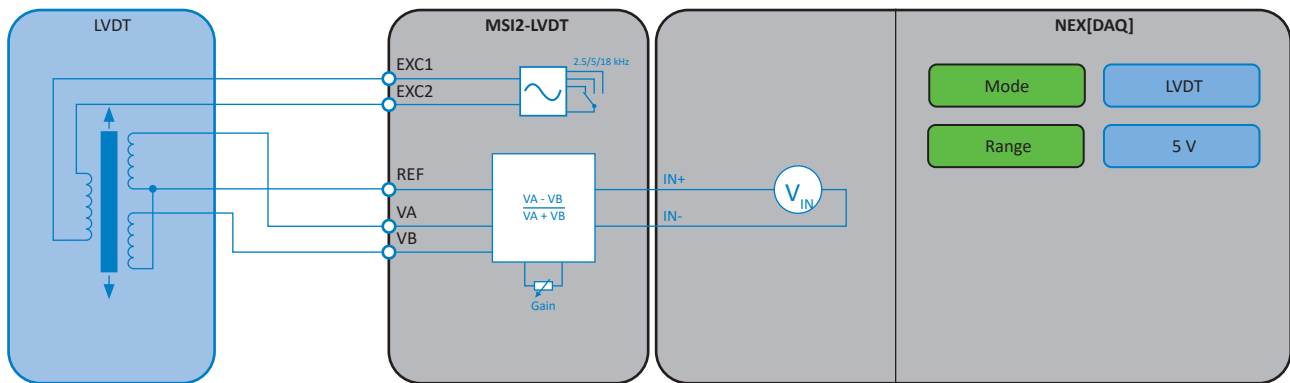

Fig. 11: Sensor connector MSI2-LVDT



Connecting a sensor

In order to connect a sensor proceed as follows:

1. Check the sensor datasheet and determine the correct connection.



2. Prepare the sensor cable.



SIGNAL CONNECTION

3. Solder the wires onto the printed circuit board.



4. Connect the MSI2-LVDT to the measurement system with an extension cable.



5. Adjust the gain-potentiometer roughly.

6. Close the housing.



7. Connect the sensor directly or via extension cable.



8. Fine adjust sensor with sensor scaling.

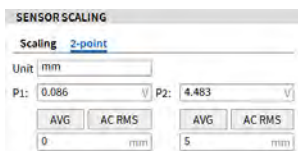

The sensor is now connected.



4 to 20 mA sensor

- ▶ Direct connection of loop powered sensors
- ▶ Simple connection without soldering



MSI2-LA-250R-20mA	
Supported sensors	4 to 20 mA, loop powered sensors
Sensor connection	Push-in spring connection, 0.14 to 0.5 mm ² , AWG 26 to 20
Input range	±25 mA

Tab. 28: Signal connection MSI2-LA-250R-20mA

SIGNAL CONNECTION

MSI2-LA-250R-20mA	
Accuracy	0.05 % of reading $\pm 4 \mu\text{A}$
Excitation voltage	AUX power, refer to simplified power schematic
Shunt resistor	250 Ω , 0.4W, 25 ppm/ $^{\circ}\text{C}$

Tab. 28: Signal connection MSI2-LA-250R-20mA

Sensor connector

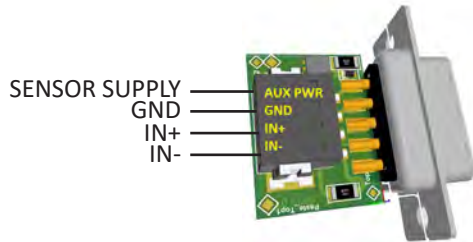
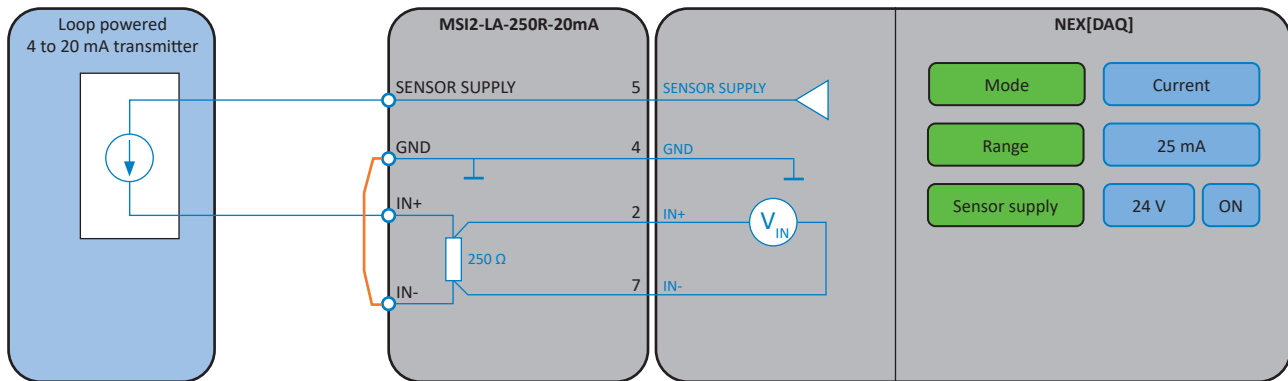
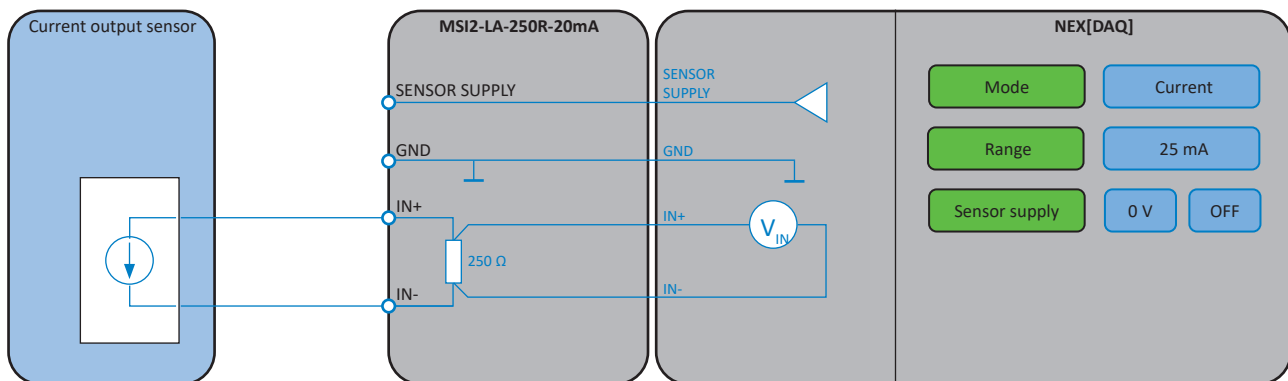

Fig. 12: Sensor connector MSI2-LA-250R-20mA

Loop powered 4 to 20 mA transmitter



Current output sensor



Working with the system

Mounting options

The following mounting options are available:

- ▶ Belt
- ▶ DIN rail
- ▶ Screws

Using NEX[DAQ] on a laptop/PC

To connect your NEX[DAQ] to a laptop or PC, it is necessary to install the OXYGEN measurement software as well as all drivers for the NEX[DAQ] before connecting it to the laptop/PC. This reference manual describes on how to install and operate your device with OXYGEN.

INFORMATION

Do not connect your NEX[DAQ] with your laptop/PC before installing any measurement software or drivers on your laptop/PC.

Requirements

System requirements

- ▶ Operating system Windows (10/11), Ubuntu (20.04/22.04) or Alma Linux 8 (not covered in this manual)
- ▶ Premium processor (Intel Core i5 7th Gen or higher, AMD Ryzen 5 or higher)
- ▶ 8 GB RAM
- ▶ USB3 or Ethernet interface

Minimum installation requirements

- ▶ OXYGEN 6.5 or newer

Advanced usage

- ▶ DEWETRON Applications: For maintenance and special device configurations

Install driver (USB only)

To start the automatic driver installation proceed as follows:

1. Ensure proper power supply and Internet connection.
2. Connect a USB-C cable with SuperSpeed capability (USB 3.x) to the port named "USB-C SS" and to the PC.
3. Wait for the driver to be installed automatically.
4. A new device with the name *ASIX AX88179 USB 3.0 to Gigabit Ethernet Adapter* will now be present in the device manager.

WORKING WITH THE SYSTEM

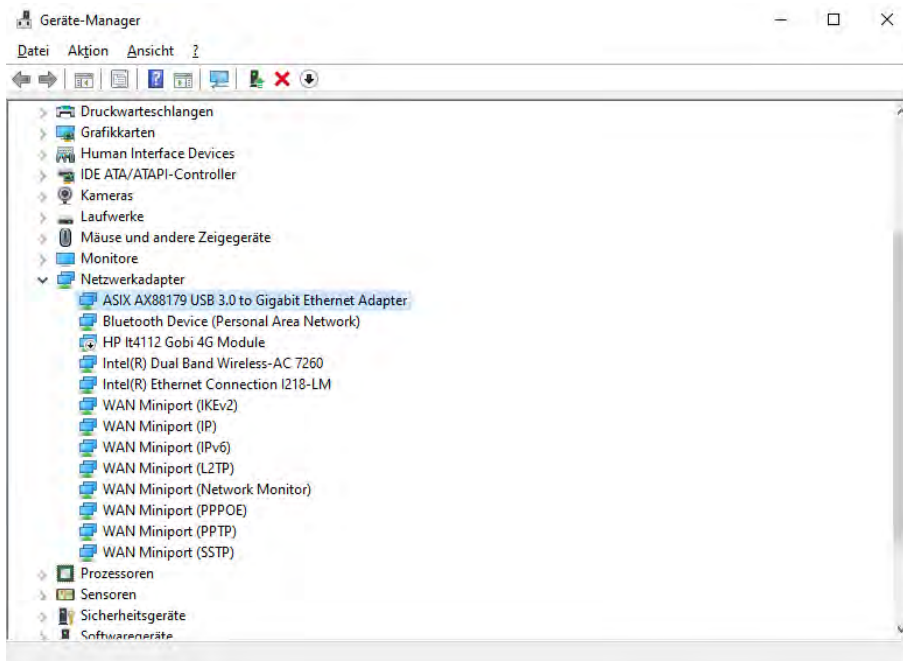

The driver installation is now completed.

Installing OXYGEN

To install the OXYGEN software on your laptop/PC proceed as follows:

1. Execute the OXYGEN installer file on the flash drive delivered with your NEX[DAQ] device and follow the instructions.

INFORMATION If you do not have the installer file yet, download the latest version from our Customer Care Center: <https://ccc.dewetron.com/pl/oxygen>.

2. Allow access through the firewall.

When you first start OXYGEN in some cases a Windows Firewall prompt will pop up blocking the software. Make sure to allow access through the firewall by clicking on "Allow access".

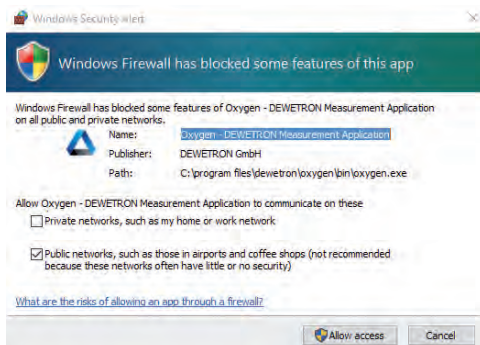

3. Load the license file (see [OXYGEN manual](#)).
4. For advanced configuration, install the DEWETRON applications by starting the installer and follow the installation instructions.

WORKING WITH THE SYSTEM



5. As soon as the installation has been finished, start OXYGEN.

INFORMATION If OXYGEN is installed the first time on your PC, the acquisition should be already running.

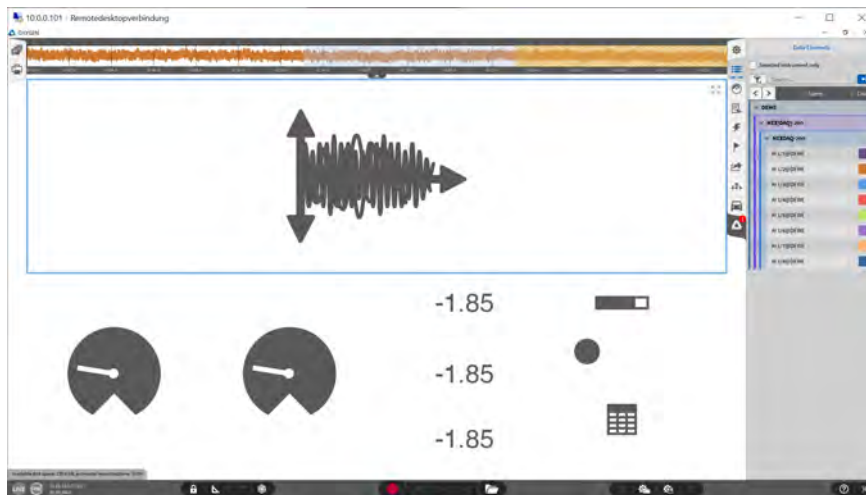

6. Open the channel list to see the measurement configuration.

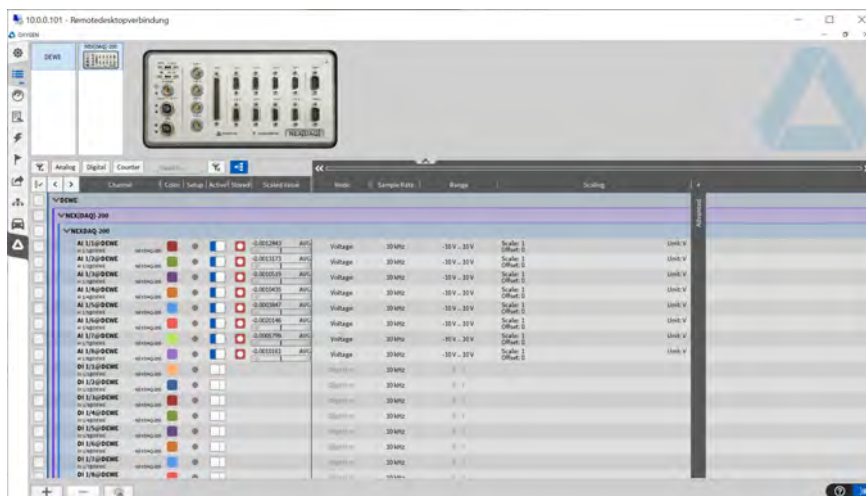

INFORMATION If no acquisition is running:

- Ensure the following settings: Go to the DEWETRON “Logo” and open the System Settings, navigate to DAQ

WORKING WITH THE SYSTEM

Hardware: TRION must be enabled.

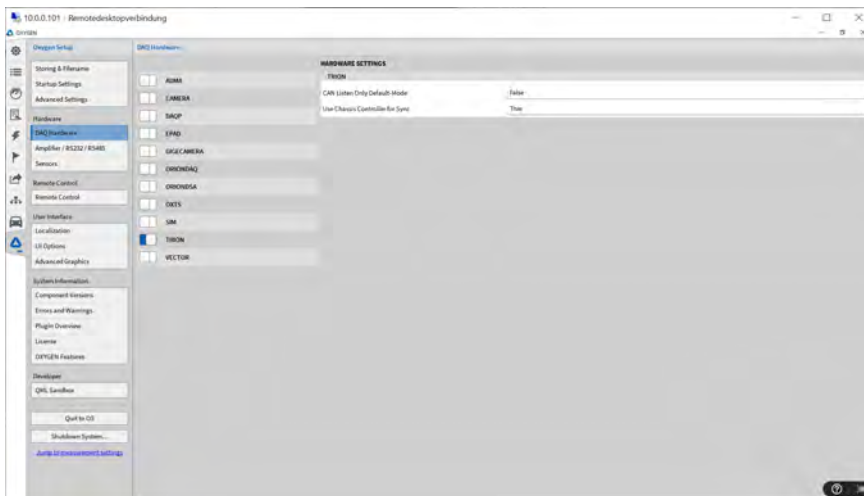

- Navigate to the “NET” tab and “Settings” for the interface settings:
- Check, if “Auto claim USB” is enabled and interface name is set to “Auto”

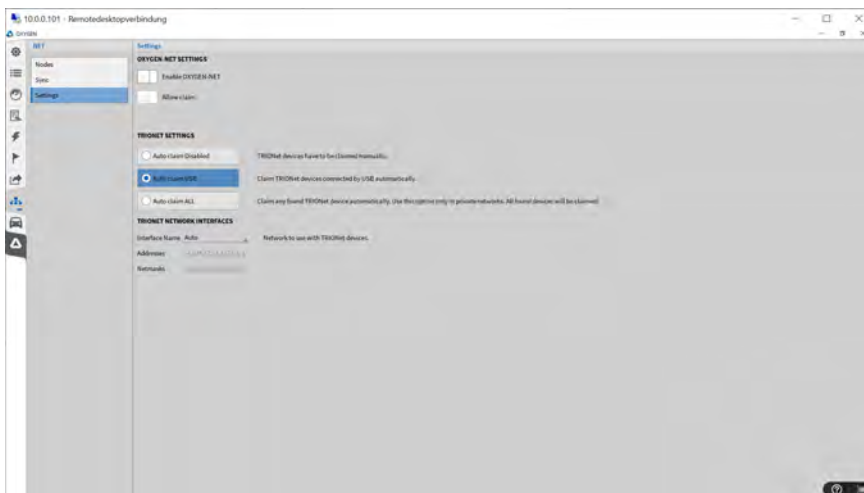

- Restart OXYGEN
7. Claim devices (in case “Auto Claim” is disabled or Ethernet is used).
With the current configuration, the devices connected to the PC via USB cable, will be claimed automatically.
 8. In case of using an Ethernet connection instead, the claiming has to be done manually:
 - Open the “Nodes” label in the “NET” settings. You can see all available devices in this view. Click on the desired node on the “Claim” button to use it for your measurement.

WORKING WITH THE SYSTEM

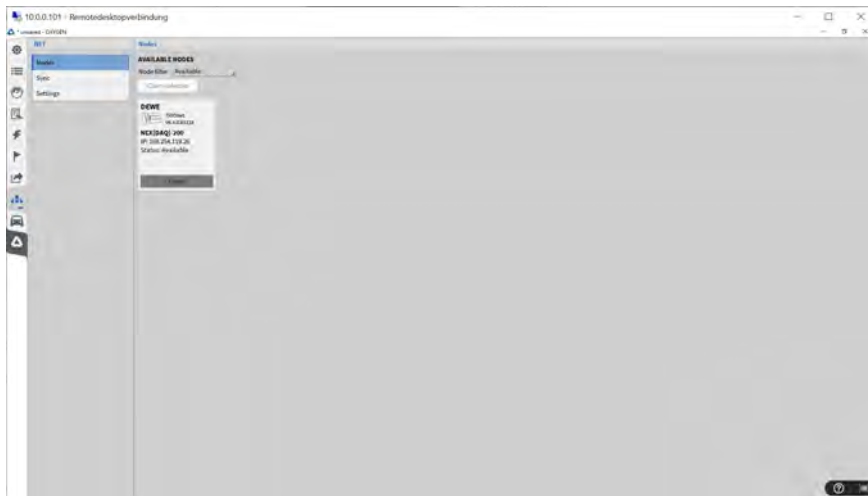

- After the claiming progress, the device should be listed under “Connected Devices”:

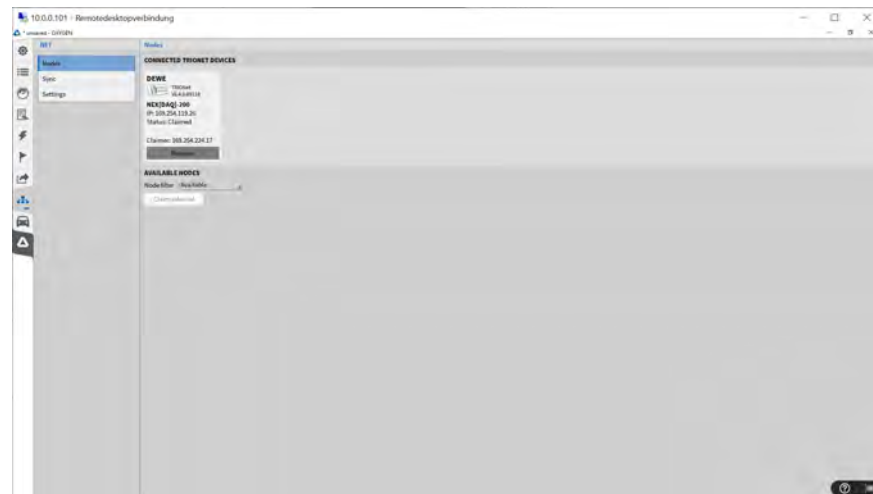

Your NEX[DAQ] is now connected with your PC/laptop and ready to use.

Advanced configuration

For further configuration of the device (friendly name, IP settings), the DEWETRON Applications must be installed.

INFORMATION Pre-requirements: OXYGEN must be closed and not running.

1. Open the DEWETRON Explorer. After a few seconds, the NEX[DAQ] devices should show up.

WORKING WITH THE SYSTEM

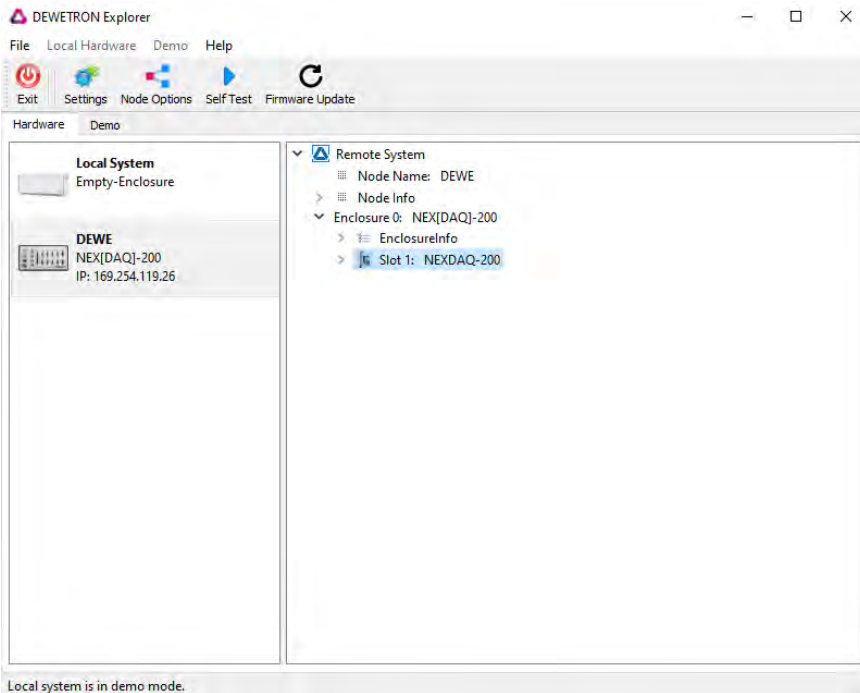

2. Select the desired device and open the Node Options.
3. Change the "IP Settings" (*change node IP*) and/or the "Device Name" (*rename node*) as desired.
and/or
update the device's software and firmware (*Software Update*).

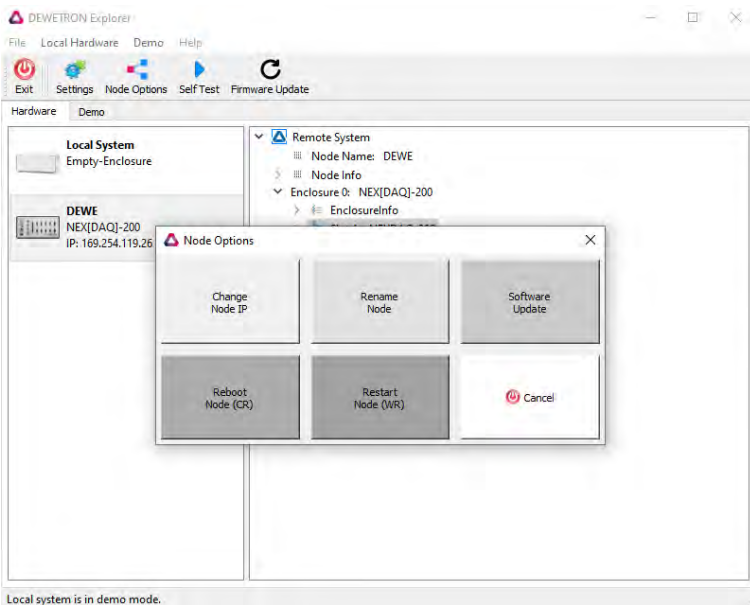

Changing IP settings

The IP Settings are used in USB and Ethernet connection mode. The USB-Connection emulates an Ethernet Port on the connected PC.

By default, the device uses link-local IP Addresses, if no DHCP server is present. This is the most convenient way of using the device.

WORKING WITH THE SYSTEM

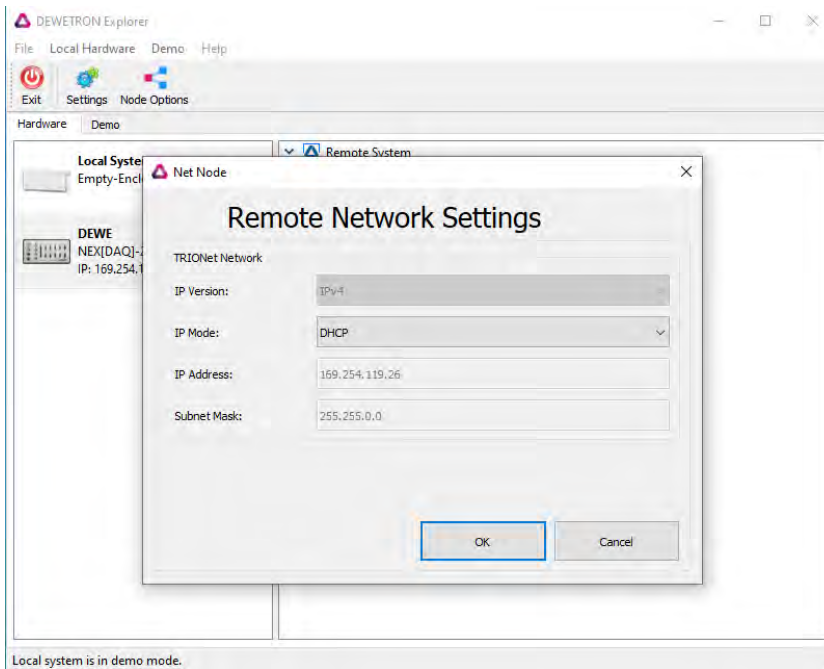

NOTICE

If a static IP is set on the PC side (outside the range of 169.254.0.0), the communication is not possible anymore.

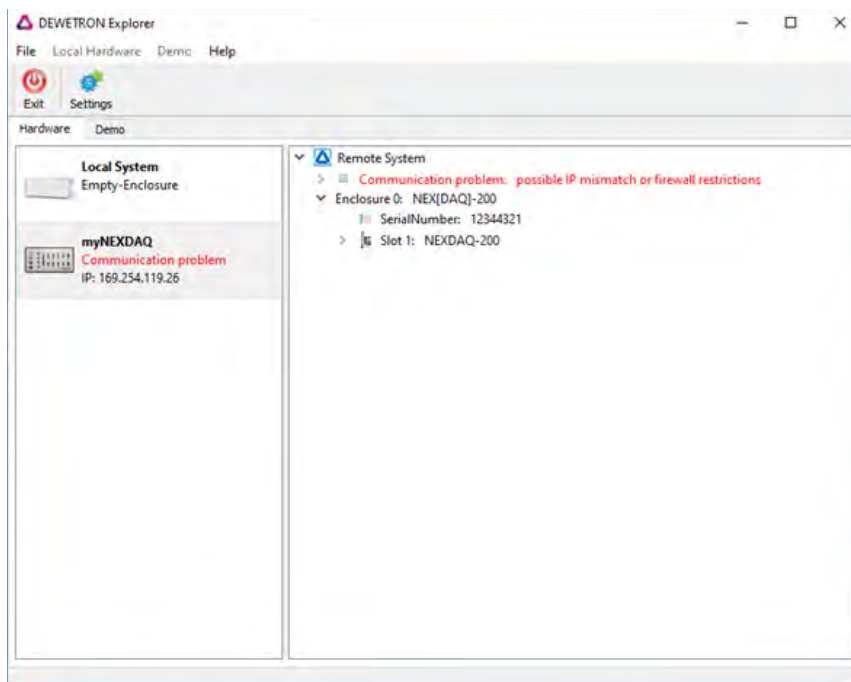

In this case, change your PC's local IP address back to DHCP/Auto.

When using several NEXDAQ devices, it is somehow useful to give the devices unique names.

WORKING WITH THE SYSTEM

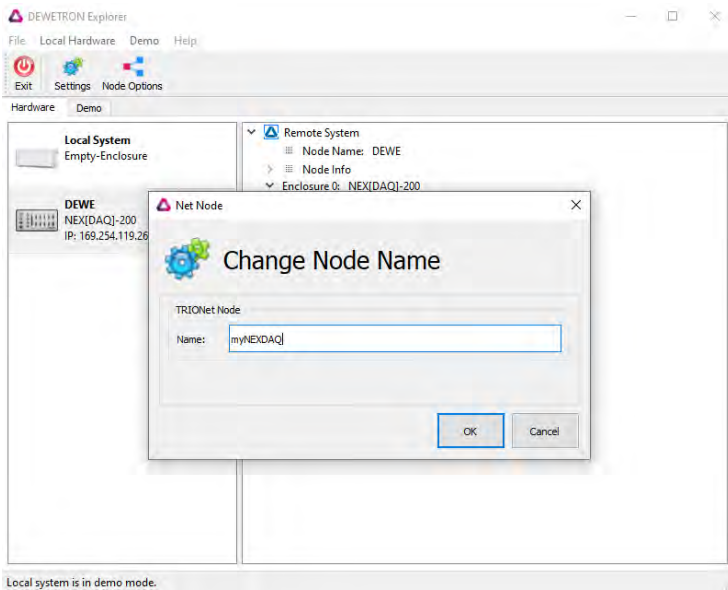

Afterwards, your OXYGEN screen will look like this:

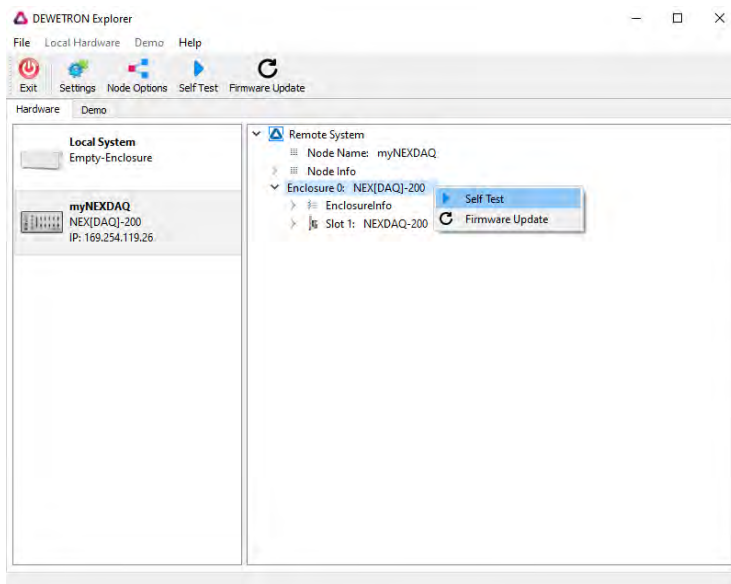
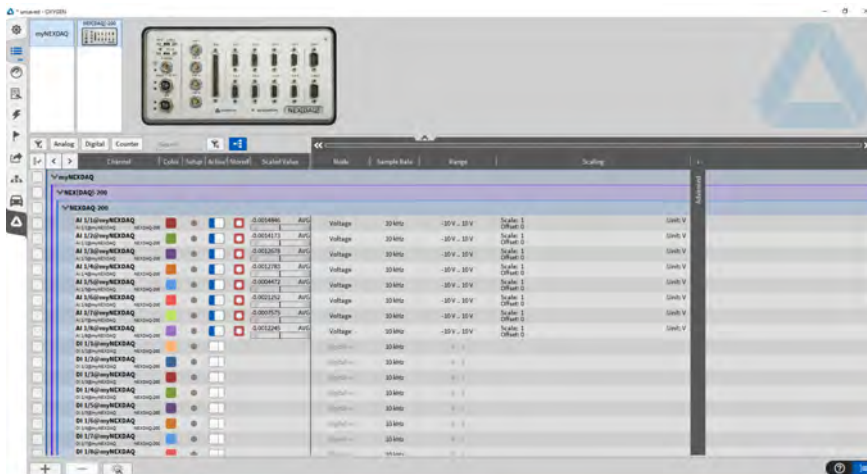

WORKING WITH THE SYSTEM

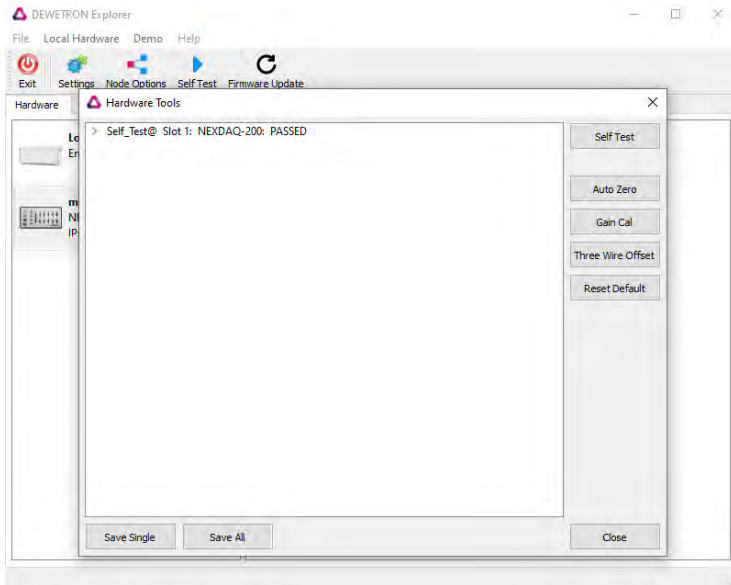

The IP settings are now changed.

TROUBLESHOOTING

Troubleshooting

Network interface

Point-to-point topology (NEXDAQ direct connected to PC):

Device (PC)	Static IP	DHCP
Static IP	OK (same IP range)	Possible problems
DHCP	Possible problems	OK

NEX[DAQ] cannot be detected if connected to laptop/PC with USB 3.0 at all.

- ▶ Check your USB cable for damages.
- ▶ Check if plugged-in properly into NEX[DAQ] as well as laptop/PC.
- ▶ Check overall cable length. The cable length must not exceed 1.8 m (6 ft). If you are using a USB 3.0 Type-C adapter, do not exceed overall cable length of 1.8 m (6 ft) and check if the adapter works properly.

Two NEX[DAQ] units are daisy-chained and implemented into an existing company network. Only one NEX[DAQ] is found.

- ▶ Contact the IT-administration. Some IT infrastructures do not allow to connect more than one device to an Ethernet plug so daisy-chaining NEX[DAQ] units or using a network switch is not possible.

Two or more NEX[DAQ] units are connected to a laptop/PC and found in DEWETRON Explorer but unfortunately measuring in OXYGEN fails.



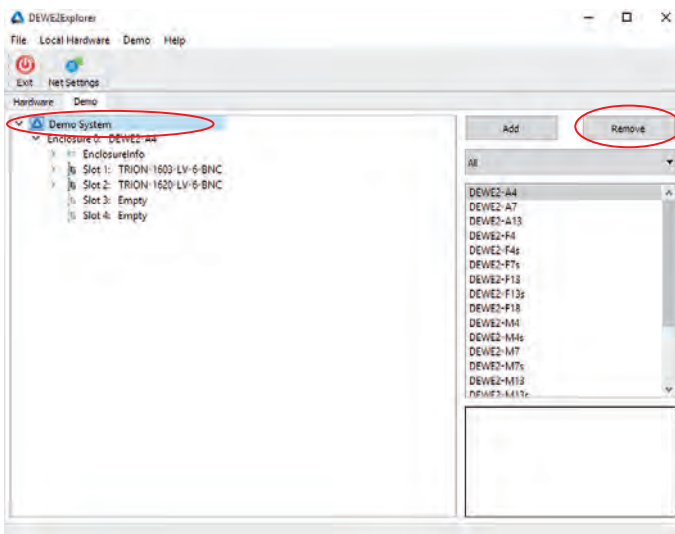





- ▶ Check if there has been a demo system created in your DEWETRON Explorer and remove it. OXYGEN cannot make any differences between virtually created demo systems and physically connected instruments. The connected NEX[DAQ] units are awaiting a clock signal from the virtually created demo system (which will not happen) and will not run in OXYGEN.
- ▶ To remove a demo system start the DEWETRON Explorer and navigate to the 'Demo' tab.
- ▶ Remove any created demo system by selecting it and hit the 'Remove' button.



Accessoires

Modular smart interfaces (MSI)

For detailed information about MSIs refer to [Signal connection via MSI on page 30](#).

Article number		Input	Sensor connection
MSI2-STG ¹⁾		Bridge-type sensors; full-bridge, half-bridge, quarter bridge 120 Ω and 350 Ω	Miniature spring terminals
MSI2-LVDT ¹⁾		LVDT and RVDT sensors, 5- or 6-wire connection	Soldering pads
MSI-BR-ACC ¹⁾		IEPE [®] sensors, typ. accelerometer, microphone	BNC
MSI2-CH-x ¹⁾		Charge type sensors up to 100 000 pC	BNC
MSI2-TH-x ¹⁾		Thermocouple sensors; standard models for type K, J, T, others on request	Mini TC socket
MSI-BR-V-200 ¹⁾		Voltage up to 70 VDC, 46.7 V _{PEAK}	BNC
MSI2-V-600 ¹⁾		Voltage up to 600 V _{DC}	Banana sockets
MSI-BR-RTD ¹⁾		RTD sensors; Pt100, Pt200, Pt500, PT1000, Pt2000; 2, 3 and 4 wire connection	Binder 712 series 5-pin socket
MSI2-250R-20mA ¹⁾		4 to 20 mA sensors	Miniature spring terminals

Tab. 29: Input types

1) MSIs are automatically detected in OXYGEN.

Further accessories

The following further accessories are available. Contact your DEWETRON supplier.

- ▶ Power supply
- ▶ Network cables
 - M12 to M12
 - RJ-45 to M12
- ▶ Adapter for CAN to XR series
- ▶ Bag

MAINTENANCE AND SERVICE

Maintenance and service

The information in this section is designed for use by qualified service personal.

Service interval

Clean dust from the chassis exterior/interior and exchange filter foam based on the operating environment.

Actions	On demand	At least once a year	Every 5 years
Clean dust from chassis exterior/interior	Depending on environmental conditions	x	-
Calibrate	-	x	-
Change CMOS battery	-	-	x

Tab. 30: Service intervals

Cleaning the system

- ▶ Clean surface of the chassis with dry lint-free cloth.
- ▶ Use a dry velocity stream of air to clean the chassis interior.
Do not use harsh chemical cleaning agents.

NOTICE



Many components within the chassis are sensitive to static discharge damage. Always wear a ground wrist strap and service the unit only in static-free environment.

WARNING



Risk of injury

Disconnect all cables before servicing the unit.



Firmware upgrade

The next steps will describe on how to update the firmware files on your NEX[DAQ].

In order to upgrade the firmware proceed as follows:

1. Open the DEWETRON Explorer.
2. Select "Node" and press "Node Options".
3. Click on "Software Update".

MAINTENANCE AND SERVICE

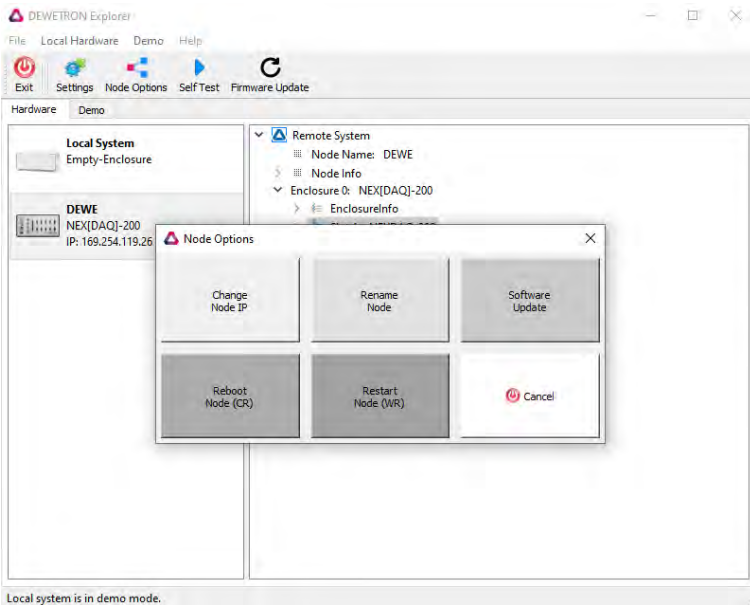

4. A browser window opens showing the update page.



5. Drag and drop the new SWU file to the "Software Update" area.

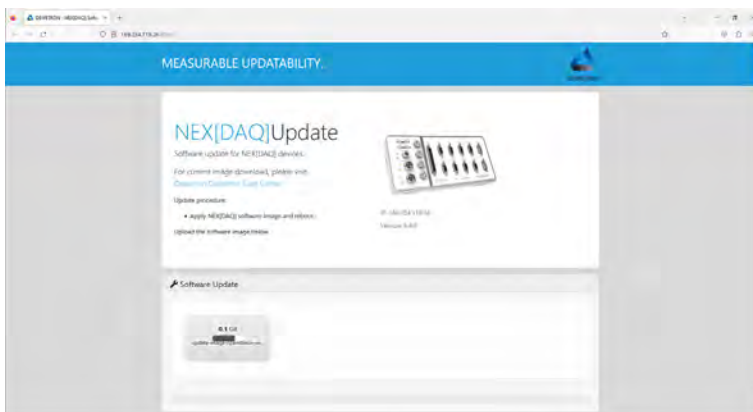

The update file will now be uploaded to the NEXDAQ.

6. Wait, until the progress is finished (this could take up to 5 minutes.)

MAINTENANCE AND SERVICE

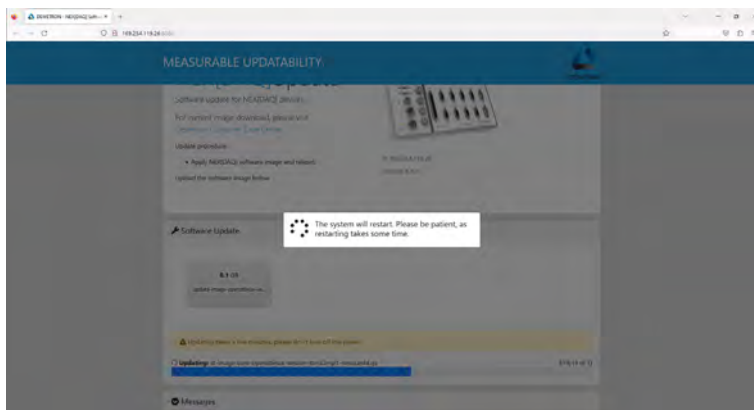

INFORMATION

If the screen does not perform an update after 5 minutes, check in the DEWETRON Explorer if the device is available. In most cases (with no static IP set) the problem is, that the NEXDAQ has another IP address. Otherwise, power cycle the device.

7. Update the firmware by right-clicking on the red text and selecting “Firmware Update”.
8. Power cycle the device and check the acquisition LED:
 - Fading orange: booting
 - Fading green: preparing acquisition and network interface
 - Green: ready

The firmware upgrade is now complete.

Updates

Windows and antivirus/security software

Before installing Windows software updates consult with DEWETRON for compatibility guidance. Also keep in mind that the use of any antivirus or other security software may slow down your system and may cause data loss.

Software updates

NOTICE

The system BIOS is protected by password. Any change in the BIOS may cause a system crash. When the system is booting, do not press ESC-button on keyboard. This may clear the BIOS settings and cause system faults.

Any change in the file structure as deleting or adding files or directories might cause a system crash.

Before installing software updates contact DEWETRON or your local distributor. Use only software packages which are released by DEWETRON. Further information is also available in the Internet (<http://www.dewetron.com>).

After power off the system wait at least 10 seconds before switching the system on again. Otherwise the system may not boot correct. This prolongs also the life of all system components.

IP settings recovery

For more information regarding an IP settings recovery contact the DEWETRON support.

Training

DEWETRON offers training at various offices around the world several times each year. DEWETRON headquarters in Austria have a very large and professional conference and seminar center, where training classes are conducted on a regular basis starting with sensors and signal conditioning, A/D technology and software operation.

Dewetron Inc. in the USA also has a dedicated training facility connected to its headquarters, located in Rhode Island.

For more information about training services visit <https://www.dewetron.com/academy>.

Calibration

Every instrument needs to be calibrated at regular intervals. The standard norm across nearly every industry is annual calibration. Before your DEWETRON data acquisition system is delivered, it is calibrated at our DEWETRON headquarters. Each of this system is delivered with a certificate of compliance with our published specifications. Detailed calibration reports from our calibration system are available for purchase with each order. We retain them for at least one year, so calibration reports can be purchased for up to one year after your system was delivered.

Support

DEWETRON has a team of people ready to assist you if you have any questions or any technical difficulties regarding the system. For any support contact your local distributor first or DEWETRON directly.

For Asia and Europe contact:

DEWETRON GmbH
Parkring 4
8074 Grambach
AUSTRIA

Tel.: +43 316 3070
Fax: +43 316 3070-90
E-Mail: support@dewetron.com
Web: <http://www.dewetron.com>

The telephone hotline is available
Monday to Friday between
08:00 and 17:00 CET (GMT +1:00).

For the Americas contact:

DEWETRON Inc. (HQ USA)
2850 South County Trail, Unit 1
East Greenwich, RI 02818
USA

Tel.: +1 401 284 3750
Toll-free: +1 866 598 3393
Fax: +1 401 284 3750
Email: support@dewetron.com
Web: <http://www.dewetron.com>

The telephone hotline is available
Monday to Friday between
08:00 and 16:30 EST

Service and repairs

We are very sorry that your DEWETRON system is not operating properly. Our team is here to ensure that your DEWETRON product is returned to peak performance as quickly as possible.

Help us to provide you with the best support by following the RMA policy.

Some problems can be solved remotely by our support team. To facilitate a quicker resolution to the problem and save unnecessary shipping costs, we ask you to first have your problem investigated by our technical support before sending your product. Contact details for our support can be found on our website. Describe the error accurately and with as much detail as possible. This helps expedite the repair process.

If a repair is necessary, complete our online [RMA form](#). You will then receive an RMA (Return Material Authorization) number and detailed instructions that identify where to ship the damaged product.

MAINTENANCE AND SERVICE

Products arriving at our repair department without RMA require follow-up calls and investigation, which lead to a longer turnaround. Only the team of DEWETRON is allowed to perform any kinds of repairs to your system to assure a safe and proper operation in future.

INFORMATION

Only the team of DEWETRON is allowed to perform any kinds of repairs to your system to assure a safe and proper operation in future. For information regarding service and repairs contact your local distributor first or DEWETRON directly.

INFORMATION

Any spare parts (screws, backplanes, cables etc.) must be obtained from DEWETRON only.

Letter of volatility

The following chart corresponds to the memory types that are used within the NEX[DAQ] system.

Volatile memory

Type	Size	User modifiable	Function	Process to delete
Micron STM32MP1 DDR3	512 MB	Yes	RAM	Power off
STMicroelectronics STM32MP1, Cache + SRAM	Cache: 384 kB SRAM: 708 kB	Cache: no SRAM: yes	Cache SRAM	Power off
Microchip LAN9668, Paket RAM + cache	Pkt-RAM: 10 kB Cache: 20 kB	Yes	RAM	Power off

Tab. 31: Volatile memory

Non-volatile memory

Type	Size	User modifiable	Function	Process to delete
eMMC Embedded Flash Storage	8 GB	Yes	Main drive for operating system, programs & drivers	DEWETRON Explorer firmware update
Flash	16 MB	Yes	FPGA Firmware	"DEWETRON Explorer firmware update
EEPROM	512 B	Yes	USB to ETH controller configuration	n.a.
SD-card slot	No SD-card mounted	Yes, when SD-Card mounted	Alternate boot device	Remove card

Tab. 32: Non-volatile memory

APPENDIX

Appendix

General

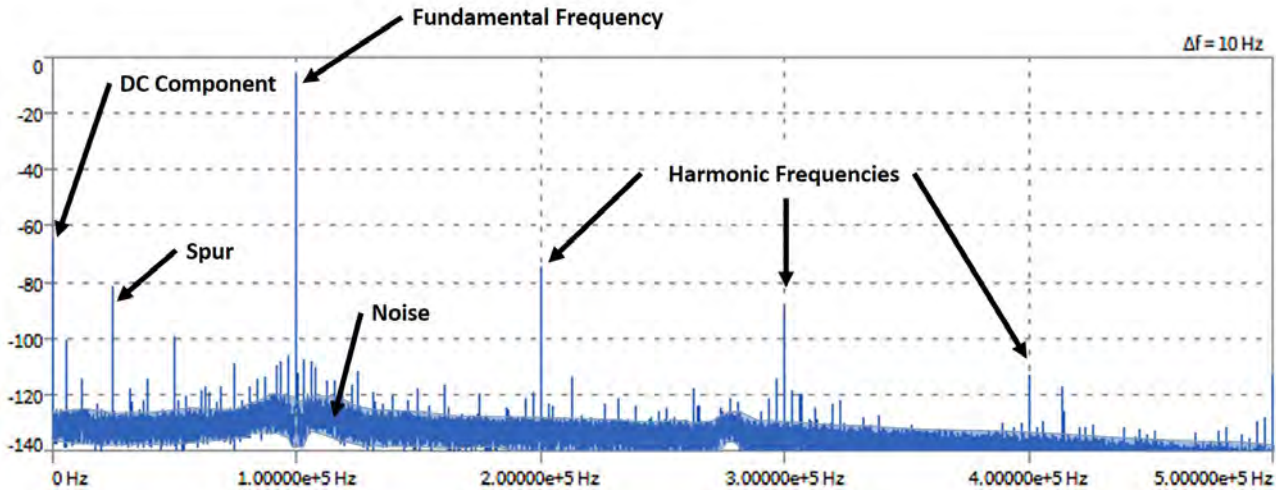

Fig. 13: FFT chart of TRION-1620-ACC

Fundamental frequency

The fundamental frequency is the component with the lowest frequency of a periodic test-signal. In the case of an ideal sine wave, the only frequency which would appear is the fundamental frequency.

Harmonic frequencies

Harmonic frequencies or Harmonics, as they are sometimes called, are frequencies that are multiples of the fundamental frequency. These disturbances are most likely caused by amplifier components and the function generator itself, which is used for testing. This is the reason why only special ultra-low noise function generators should be used for measurements.

Spurs

These are frequency components that appear in signals due to the electrical components of the instrument, but which are not harmonics.

Noise

Noise includes all voltage and frequency components in the signal which are present during measurement or generation but not present in the ideal or present signal, except for spurs and harmonics.

DC component

The DC component is a spur with a frequency of 0 Hz.

Testing

General information about testing

For the measurement of the SNR, SFDR, THD and CMRR the eighth-order Bessel low-pass filter is set in Auto-mode, if a filter is available and if not stated otherwise. While measuring the SNR and SFDR a short circuit is placed at the channel of testing. For the measurement of THD a sine wave is used as the input signal for testing. At a sample rate higher than 100 kS/s, a frequency of 1 kHz and an amplitude of 70 % of the maximum input range is used. To measure the CMRR, both inputs are provided with the same sinusoidal signal which amplitude should be adjusted to a value that utilizes the range used for measurement. The CMRR is then directly measured from the FFT chart. As a function generator only ultra-low distortion function generators should be used. In our case we use the Model D360 Ultra Low Distortion Function Generator from Stanford Research Systems.

SNR

The SNR, or Signal-to-noise ratio, is the ratio of the input power value to the root-mean-square value of the noise power value. The RMS of the noise power excludes the fundamental frequency, all harmonics and spurs and the DC component.

To calculate the SNR, the AC_{RMS} is measured with a short circuit on the input channel. Afterwards the SNR is calculated depending on the range, used during measurement, with the equation below. Every AC_{RMS} measurement, which is taken over the period of 1 second, is done five times and the mean of these measurements is used in the equation.

Formula

$$SNR [dB] = \left| 20 \times \log_{10} \left(\frac{AC_{RMS} [V] \times \sqrt{2}}{range [V]} \right) \right|$$

Equ. 1: Calculating the SNR from AC_{RMS} depending on the range

Example for TRION-1802/1600-dLV-32 at 10 V range and a sample rate of 50 kS/s

$$SNR [dB] = \left| 20 \times \log_{10} \left(\frac{5.6068 V \times 10^{-5} \times \sqrt{2}}{10 V} \right) \right| = 102 dB$$

Equ. 2: Calculating the SNR

If the range is specified as AC value then SNR is calculated from:

Formula

$$SNR [dB] = \left| 20 \times \log_{10} \left(\frac{AC_{RMS} [V]}{range_{AC} [V]} \right) \right|$$

Equ. 3: Calculating the SNR with range as AC value

Example for TRION-1820-POWER at 1000 V range and a sample rate of 1000 kS/s:

$$SNR [dB] = \left| 20 \times \log_{10} \left(\frac{0.00954 V}{1000 V} \right) \right| = 100 dB$$

Equ. 4: Calculating the SNR

APPENDIX

SFDR

The SFDR, or spurious free SNR or spurious free dynamic range can be defined as the free range between the signal amplitude of the fundamental frequency and the spur with the heights power value, excluding all harmonics and the DC component as shown in Fig. 14.

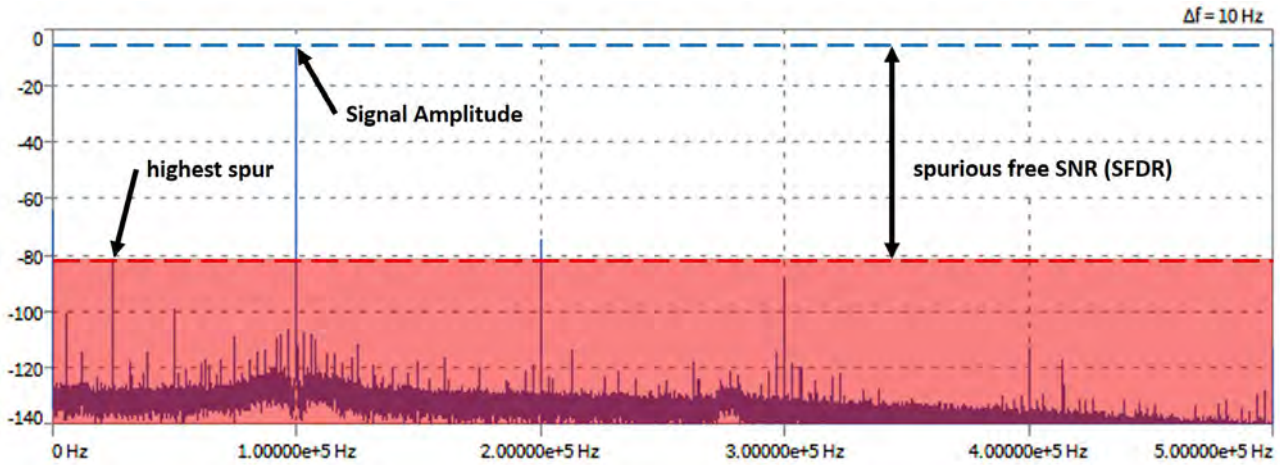

Fig. 14: SFDR in a FFT chart with input signal (alternative method)

The SFDR can also be measured as the highest spur with a short circuit on the input channel. This method, as used by DEWETRON, automatically excludes all harmonics and defines the SFDR as the highest spur seen in the FFT chart, excluding the DC component, as shown in Fig. 15.

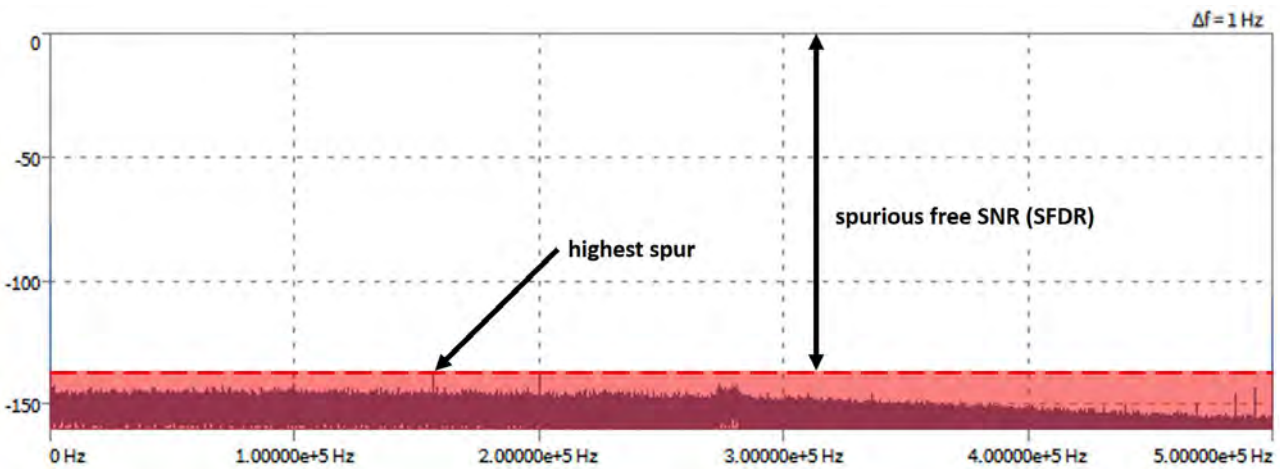

Fig. 15: SFDR in a FFT chart without input signal (DEWETRON)

ENOB

The ENOB, or Effective Number of Bits, is a characteristic value that relates the SNR with bits of resolution, a common specification of data converters. The ENOB is directly calculated from the SNR.

Formula

$$ENOB [Bit] = \frac{SNR [dB] - 1.76 \text{ dB}}{6.02 \text{ dB}}$$

Equ. 5: Calculating the ENOB from SNR

Example for TRION-1802/1600-dLV-32 at 10 V range and a sample rate of 50 kS/s

$$ENOB [Bit] = \frac{102 \text{ dB} - 1.76 \text{ dB}}{6.02 \text{ dB}} = 16.65 \text{ Bit} \approx 16.7 \text{ Bit}$$

Equ. 6: Calculating the ENOB

THD

The THD, or total harmonic distortion, is defined as the root-mean-square value of the first five harmonics of the fundamental frequency compared to the fundamental frequency. It is possible to calculate the THD as it is shown in equation 3 (with harmonics stated in [dB]) and equation 4 (with harmonics stated in [V]), if the amplitudes of the harmonics are expressed with respect to the input frequency. Fig. 17 shows how the harmonics are measured from the FFT, when the maximum peak in the FFT is equal to 0 dB.

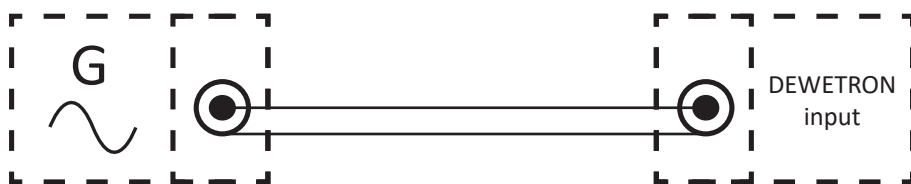

Fig. 16: Schematic circuit diagram of THD measurement

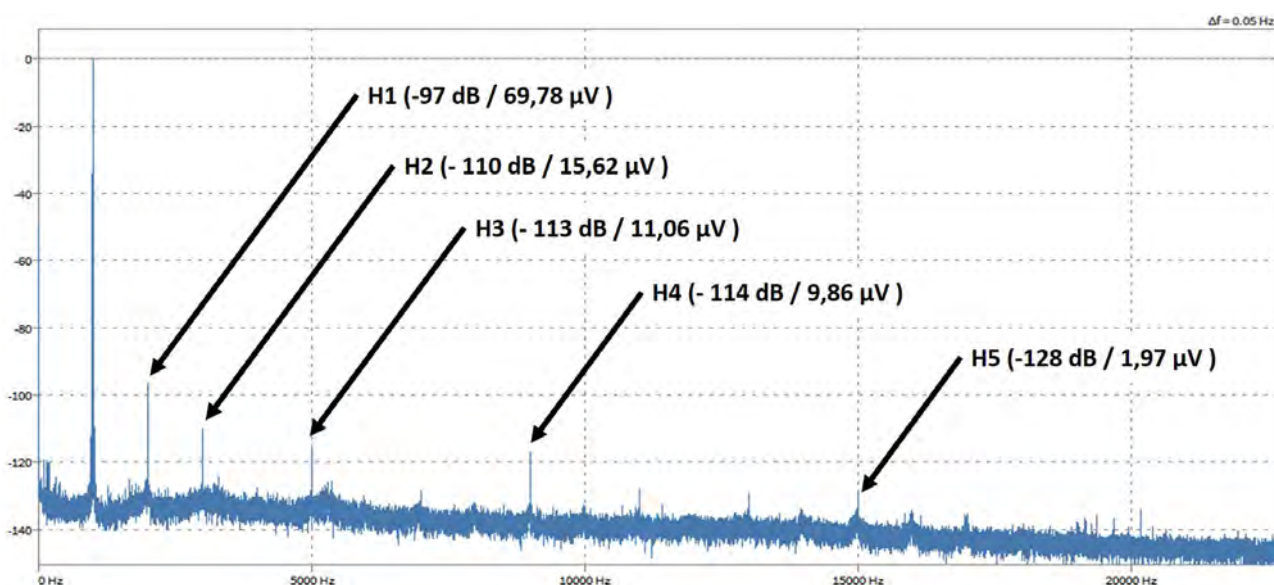

Fig. 17: THD measurement of TRION-1802/1600-dLV-32 (@50 kS/s) where $U_f = 4.94 \text{ V}$ equals 0 dB

APPENDIX

Formula

$$THD [dB] = 10 \times \log_{10} \left(10^{\frac{H_1 [dB]}{10 \text{ dB}}} + 10^{\frac{H_2 [dB]}{10 \text{ dB}}} + 10^{\frac{H_3 [dB]}{10 \text{ dB}}} + 10^{\frac{H_4 [dB]}{10 \text{ dB}}} + 10^{\frac{H_5 [dB]}{10 \text{ dB}}} \right)$$

Equ. 7: Calculating the THD from harmonics [dB] - H: Harmonics [dB]

$$THD [dB] = 20 \times \log_{10} \left(\frac{\sqrt{U_{H1}^2 [V] + U_{H2}^2 [V] + U_{H3}^2 [V] + U_{H4}^2 [V] + U_{H5}^2 [V]}}{U_f [V]} \right)$$

Equ. 8: Calculating the THD from harmonics [V] - UH: Harmonics [V], Uf: Fundamental (amplitude of test signal) [V]

Example for TRION-1802/1600-dLV-32 at 10 V range and a sample rate of 50 kS/s with $U_f = 4.94 \text{ V}$; (data from Fig. 17):

$$THD = 10 \times \log_{10} \left(10^{\frac{-97 \text{ dB}}{10 \text{ dB}}} + 10^{\frac{-110 \text{ dB}}{10 \text{ dB}}} + 10^{\frac{-113 \text{ dB}}{10 \text{ dB}}} + 10^{\frac{-114 \text{ dB}}{10 \text{ dB}}} + 10^{\frac{-128 \text{ dB}}{10 \text{ dB}}} \right) = -96.6 \text{ dB}$$

Equ. 9: Calculation of THD from harmonics [dB]

$$THD = 20 \times \log_{10} \left(\frac{\sqrt{(69.78 \text{ V} \times 10^{-6})^2 + (15.62 \text{ V} \times 10^{-6})^2 + (11.06 \text{ V} \times 10^{-6})^2 + (9.86 \text{ V} \times 10^{-6})^2 + (1.97 \text{ V} \times 10^{-6})^2}}{4.94 \text{ V}} \right) = -96.6 \text{ dB}$$

Equ. 10: Calculation of THD from harmonics [V]

CMRR

The CMRR or common-mode rejection ratio of an ADC in differential mode (ADC input voltage is the difference between the two inputs) is the capability to filter out the input signal which is common to both inputs. It is often the case that noise is common to both terminals while the relevant information is contained in the voltage difference between the two inputs. A high CMRR results in a good noise rejection common to both terminals while the relevant signal information is preserved. To measure the CMRR the same input signal is applied to both inputs, as seen in Fig. 18 and afterward directly measured from the FFT chart as seen in Fig. 19.

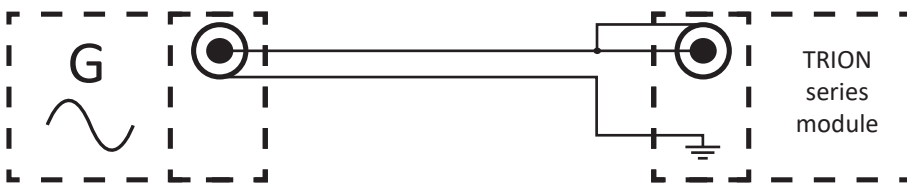

Fig. 18: Schematic circuit diagram of CMRR measurement

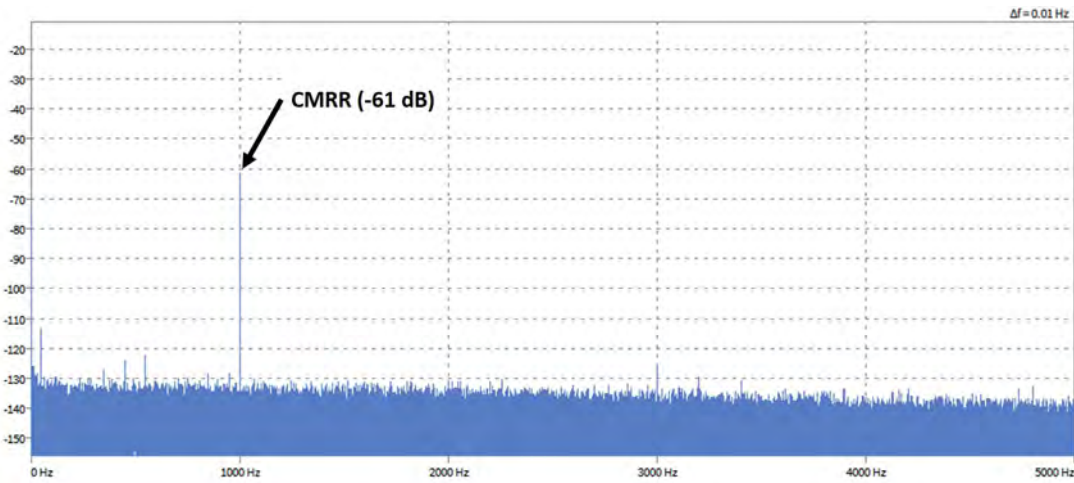

Fig. 19: Measurement of CMRR in FFT chart of TRION-1620-ACC (>2 V range @ 1 kHz)

Fig. 20 shows the CMRR response, depending on the input frequency, of all four voltage channels of the TRI-ON-1820-POWER-4.

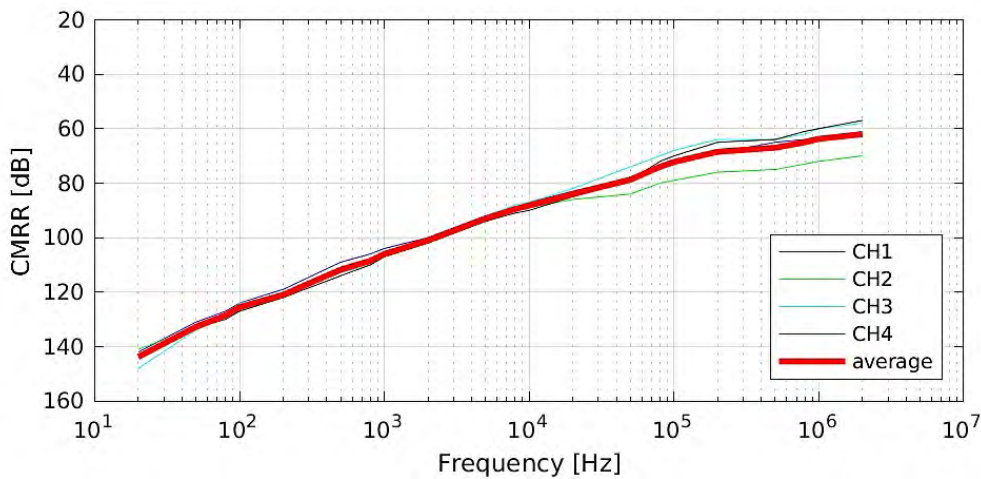

Fig. 20: CMRR over frequency response of a TRION-1820-POWER-4 (V inputs) (not a directly measured FFT chart)

Phase mismatch

We state all our phase mismatch values Δt in the unit nanoseconds [ns]. To convert the phase mismatch in the unit degree [deg] Equ. 11 is needed, as shown below. As the test-frequency f , we typically use 1 kHz.

Formula

$$\varphi [deg] = \frac{\Delta t [ns] \times 360 \text{ deg} \times f [Hz]}{10^9} \leftrightarrow \Delta t [ns] = \frac{\varphi [deg]}{360 \text{ deg} \times f [Hz]} \times 10^9$$

Equ. 11: Calculating phase mismatch from [ns] in [deg] and conversely

Example for TRION-1802/1600-dLV-32 at 10 V range at 1 kHz test signal measured between CH1 and CH2:

$$\varphi [deg] = \frac{18.33 \text{ ns} \times 360 \text{ deg} \times 1000 \text{ Hz}}{10^9} \approx 0.0066 \text{ deg} \leftrightarrow \Delta t [ns] = \frac{0.0066 \text{ deg}}{360 \text{ deg} \times 1000 [Hz]} \times 10^9$$

Equ. 12: Calculating phase mismatch from [ns] in [deg] and conversely

APPENDIX

Glossary

Isolation voltage

WARNING



Danger to life due to electric shock

Exceeding the isolation voltage may cause danger to life and physical condition (electric shocks, burn).

NOTICE

Exceeding the isolation voltage causes the damage of the measurement input in most every case, also other components inside the measurement unit could be affected.

This value indicates the highest voltage that can be applied between an input pin and the reference potential without causing an isolation breakdown (uncontrolled current flow).

The isolation voltage is basically limited by creepage and clearance distances, the insulation material, and the used components. The given specification has been proven by high voltage tests on a systematical basis and by sample testing on the released product.

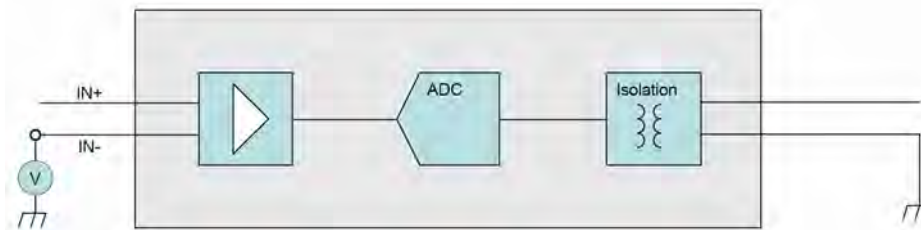

Fig. 21: Isolation voltage

Input ranges

DEWETRON measurement equipment provides one or more input range(s). An input range indicates the highest possible value which can be displayed, similar to the limit position of a dial instrument.

Voltage and current values (V and A) are generally to be read as V_{RMS} and A_{RMS} values, especially if they are followed by a peak value (e.g. $5 V_{RMS}$ ($10 V_{PEAK}$)).

If a V value is prefixed by a plus-minus sign, the following value is to be interpreted as V_{DC} value, unless otherwise stated.

INFORMATION

The value of the input range does not give any information concerning the allowable scope of application refer to Fig. 20 on page 67.

Rated input voltage to earth

Rated input indicates the allowable scope of application of a measurement input according to the IEC/EN 61010-2-30 (Safety Requirements for Electrical Equipment for Measurement, Control, and Laboratory Use - Part 2-030: Particular Requirements for Equipment Having Testing or Measuring Circuits) standard. DEWETRON equipment and measurement inputs are always specified according to this stated standard. Furthermore, the compliance tests are carried out by a 3rd party laboratory.

The rated input value specifies the highest possible voltage which can be applied to the measurement input. The IEC/EN 61010-2-30 additionally describes certain measurement categories within a public power grid (see also overvoltage categories IEC/EN 60664-1). Thus, measurement circuits can be applied according to their specification to the power grid categories as stated below:

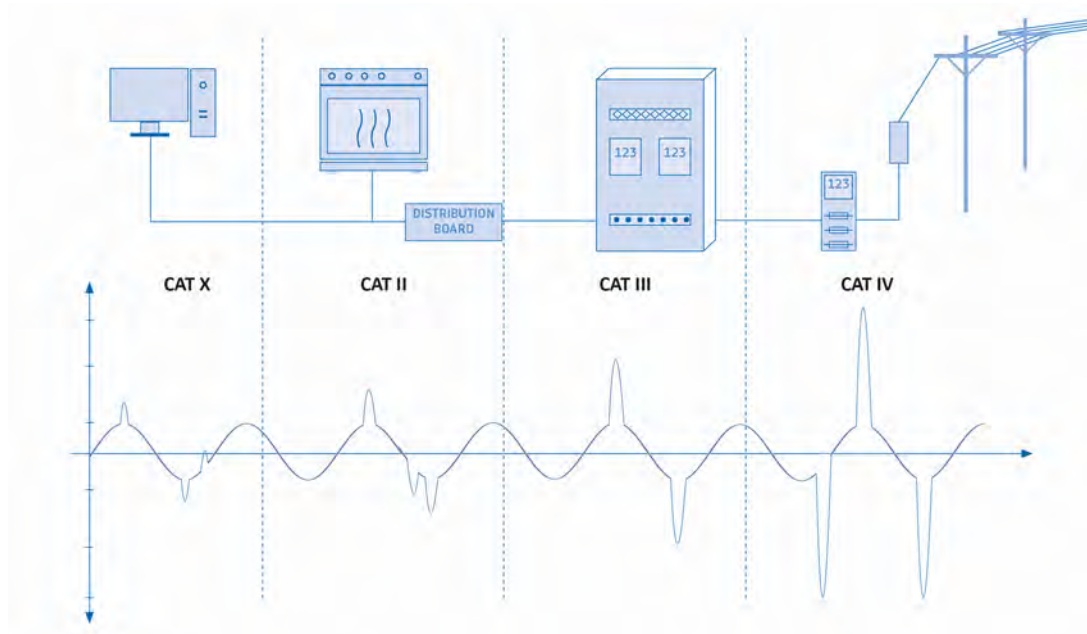

Fig. 22: Rated input voltage

The isolation is tested according to the IEC/EN 61010-2-30. The level of the isolation voltage depends on the rated input voltage and on the measurement category. Since potential overvoltage phenomena are higher within higher power grid categories, the isolation voltage needs to be higher too.

If there is no measurement category specified, the measurement input is not appropriate to be applied to a public power grid.

EXAMPLES

▶ Rated input 600 V CAT II

The measurement input can be connected to a public power grid within the category II as long as the voltage of the grid does not exceed $600 V_{\text{RMS}}$ or $600 V_{\text{DC}}$. If there is a measurement category specified, the voltage value stated is always considered to be RMS or DC.

▶ Rated Input $600 V_{\text{RMS}}$

This measurement input is not intended to be connected within an on-board power system of a train for instance.

APPENDIX

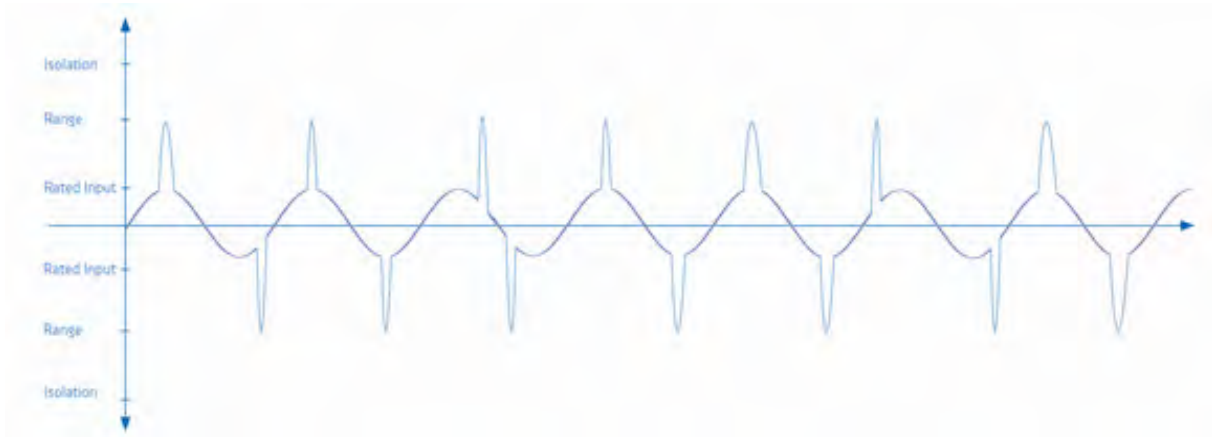

Fig. 23: Relation between rated input, input ranges and isolation voltage

Common mode voltage

Common mode voltage indicates the highest possible voltage between the two input pins of a channel (e.g. IN+ and IN-) and the reference potential (GND) without clipping the wanted signal.

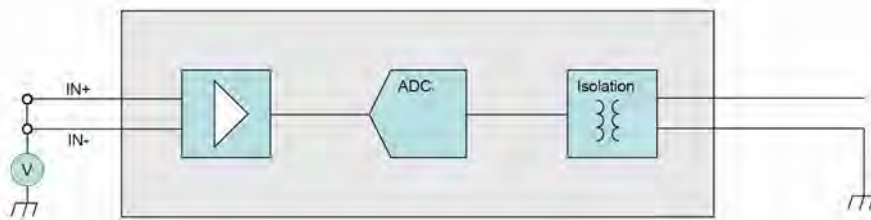

Fig. 24: Common mode voltage

In the very most cases the value of the common mode voltage corresponds to the value of the isolation voltage.

Overvoltage protection

This value indicates the highest possible voltage which will not overload the input protection circuit when applied between two pins of one channel.

Exceeding this value causes the damage of the measurement input in most every case, also other components inside the measurement unit could be affected and it is furthermore a threat to life and physical condition (electric shocks, burn).

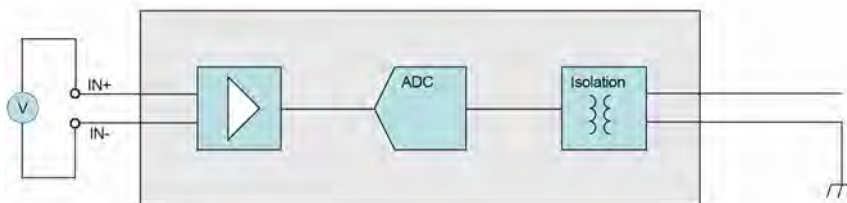

Fig. 25: Overvoltage protection

Max. DC voltage @ AC coupling

The given value refers to input AC coupled inputs only. Max. DC voltage @AC coupling specifies the highest allowed direct voltage component on the measurement input, when the coupling mode is switched to “Coupling AC”.

Bus pin fault protection

The specification of bus pin fault protection refers to the wiring of bus systems (e.g. CAN, RS-485, etc.) only. The value indicates the highest voltage which will not destroy the bus input or output when applied between the bus wiring and ground by accident.

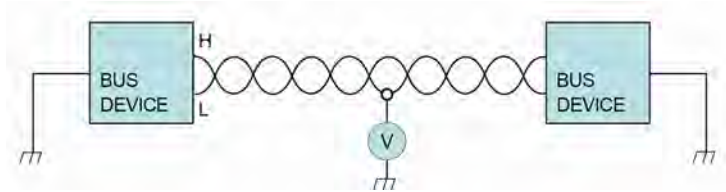

Fig. 26: Bus pin fault protection

IP rating

Depending on the installation site and conditions, electrical and electronic devices and equipment must be protected by an enclosure against the ingress of dirt, dust, water or even body parts and objects in order to prevent hazards to persons or failure, e.g. due to water, corrosion or possibly conductive dirt. Mechanical stress due to impact must also be prevented for reliable function and safe use. For this purpose, a group classification has been made in the form of the IP protection classes, which facilitates the selection of devices and housings according to the application requirements.

The IP (ingress protection) codes indicate waterproofness, protection against ingress of foreign bodies and protection against contact. The rating consists of the letters IP followed by two digits, the higher the number the better the protection. Sometimes a number is replaced by X, which indicates that the enclosure is not rated for that specification.

The protection class is always built up according to the following scheme: IPXX(x)

- ▶ The 1st digit stands for protection against contact and especially against foreign bodies,
- ▶ The 2nd digit stands for water protection,
- ▶ The 3rd digit can be occupied by supplementary letters for protection against contact.

If only one of the numbers is important, an X is assigned to the other digit. This is how combinations such as IP5X and IPX4 come about.

Tab. 33 shows the various rating classes:

APPENDIX

1 st digit	Intrusion protection	2 nd digit	Moisture protection	3 rd digit	Contact protection
0	No protection.	0	No protection.	A	Protected against access to hazardous active parts with the back of the hand.
1	Protected against solid objects over 50 mm, e.g. accidental touch by hands.	1	Protected against vertically falling drops of water, e.g. condensation.	B	Protected against access to dangerous active parts with a finger.
2	Protected against solid objects over 12 mm, e.g. fingers.	2	Protected against direct sprays of water up to 15 degrees from the vertical.	C	Protected against access to dangerous active parts with a tool.
3	Protected against solid objects over 2.5 mm, e.g. tools & wires.	3	Protected against direct sprays of water up to 60 degrees from the vertical.	D	Protected against access to dangerous active parts with a wire.
4	Protected against solid objects over 1 mm, e.g. wires and nails.	4	Protected against water splashed from all directions, limited ingress permitted.	-	--
5	Protected against dust limited ingress, no harmful deposits.	5	Protected against low pressure jets of water from all directions, limited ingress permitted.	-	
6	Totally protected against dust.	6	Protected against strong jets of water, e.g. on ships deck, limited ingress permitted.	-	
-	-	7	Protection against temporary immersion in water.	-	
-	-	8	Protection against permanent immersion in water (water-proof).	-	
-	-	9	Protection against high pressure and steam cleaners.	-	

Tab. 33: IP rating reference chart

CERTIFICATE OF CONFORMITY

CE certificate of conformity



Manufacturer

DEWETRON GmbH

Address

Parkring 4
8074 Grambach, Austria
Tel.: +43 316 3070-0
Fax: +43 316 3070-90
Email: sales@dewetron.com
<http://www.dewetron.com>

Name of product

NEX[DAQ]

Kind of product

Data acquisition instrument

The product meets the regulations of the following EC-directives:

2014/35/EU

Directive of the European Parliament and of the Council of 26 February 2014 on the harmonization of the laws of the Member States relating to the making available on the market of electrical equipment designed for use within certain voltage limits

2014/30/EU

Directive of the European Parliament and of the Council of 26 February 2014 on the harmonisation of the laws of the Member States relating to electromagnetic compatibility (recast)

The accordance is proved by the observance of the following standards:

L V E M C	Safety	IEC 61010-1:2010, Pol. deg. 2	
	Emissions	EN 61000-6-4	EN 55011 Class A
	Immunity	EN 61000-6-2	Group standard

Graz, April 27, 2023

Place / Date of the CE-marking

Ing. Thomas Propst / Manager Total Quality